

# PHYSICS 1B – Fall 2007



## Electricity & Magnetism



Monday October 1, 2007  
Course Week 1

Professor Brian Keating  
SERF Building. Room 333

# Physics 1B

## *Electricity & Magnetism!*

- Professor – Brian Keating  
[bkeating@ucsd.edu](mailto:bkeating@ucsd.edu)
- Office hours: Mondays 2-3p,
- **Office Location: SERF Building, Room 333**
- Lectures: MWF WLH 2005 10-10:50p
- **Quizzes: One every other week**
- 4 total quizzes – you are allowed to drop 1 quiz, so no makeup quizzes ☹
- **Grade**
  - Quizzes 60% (best 3 out of 4)
  - Final exam 40%
  - Extra credit 5%
  - Final exam in **WLH 2005**

That's it! What about homework????

# Office Hours: My office is in the Science & Eng. Research Facility = “SERF Building”

You want this “side” of SERF



SERF from W/LH

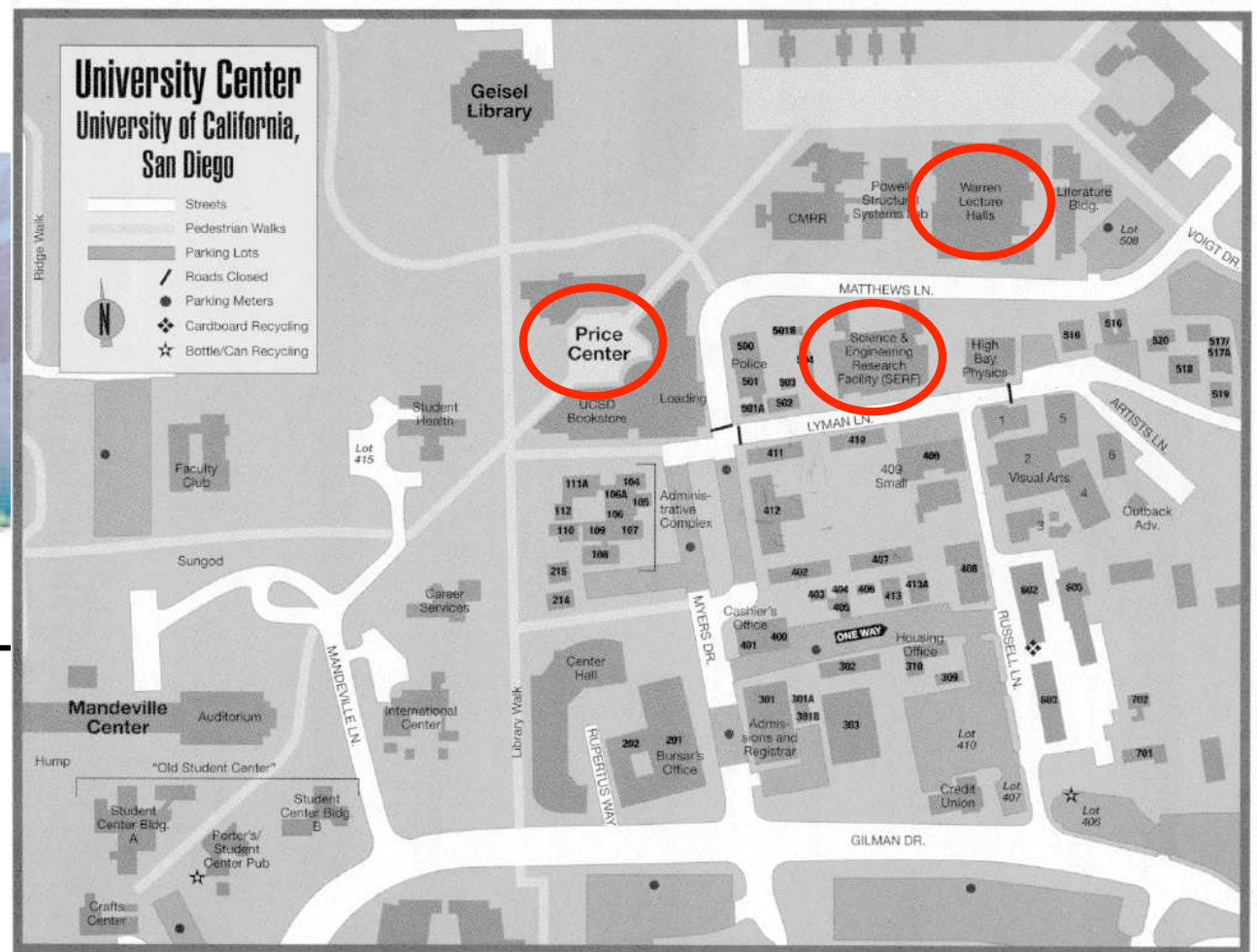

# Today's Plan

- Review Policies
- Electric Force: Coulomb's Law

# Logistical Stuff

- Last day to add a class: Friday, October 12

# Clickers

- Buy them ASAP if you want Extra Credit

# Detecting charge - Electroscope

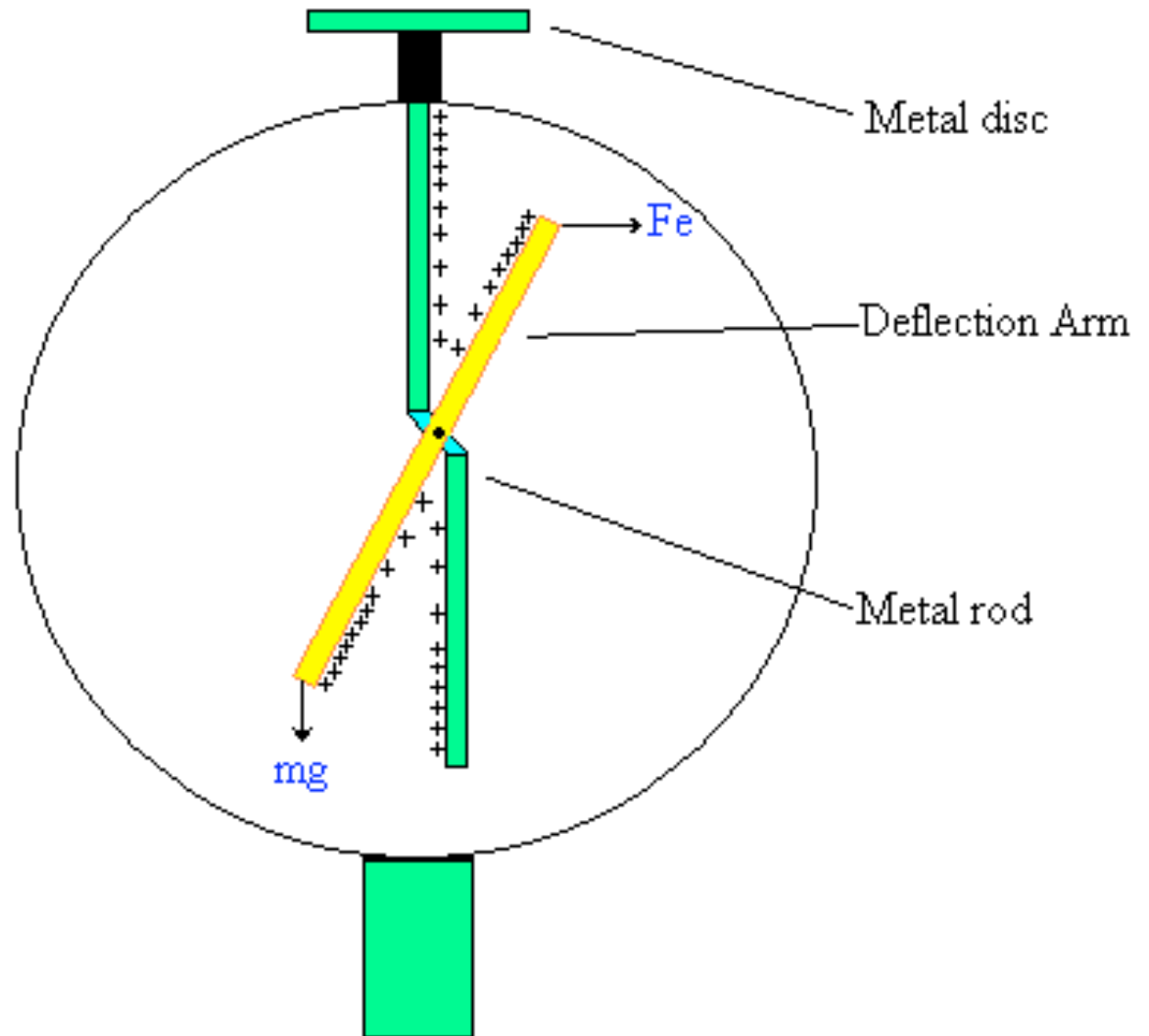

Figure 1: Electroscope

# Charging by Rubbing

Triboelectric sequence

Fur	Positive
Glass	
Silk	
Cotton	
Wood	
Rubber	negative

↑

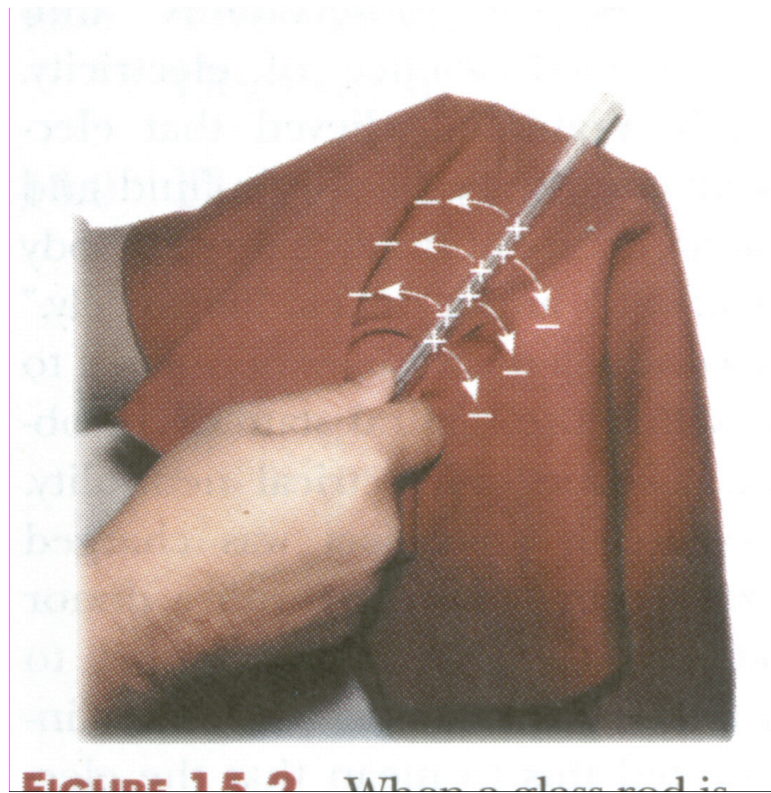

Negative charges transferred from glass to silk



# Charging by conduction

Charged rubber rod transfers electrons to metal sphere

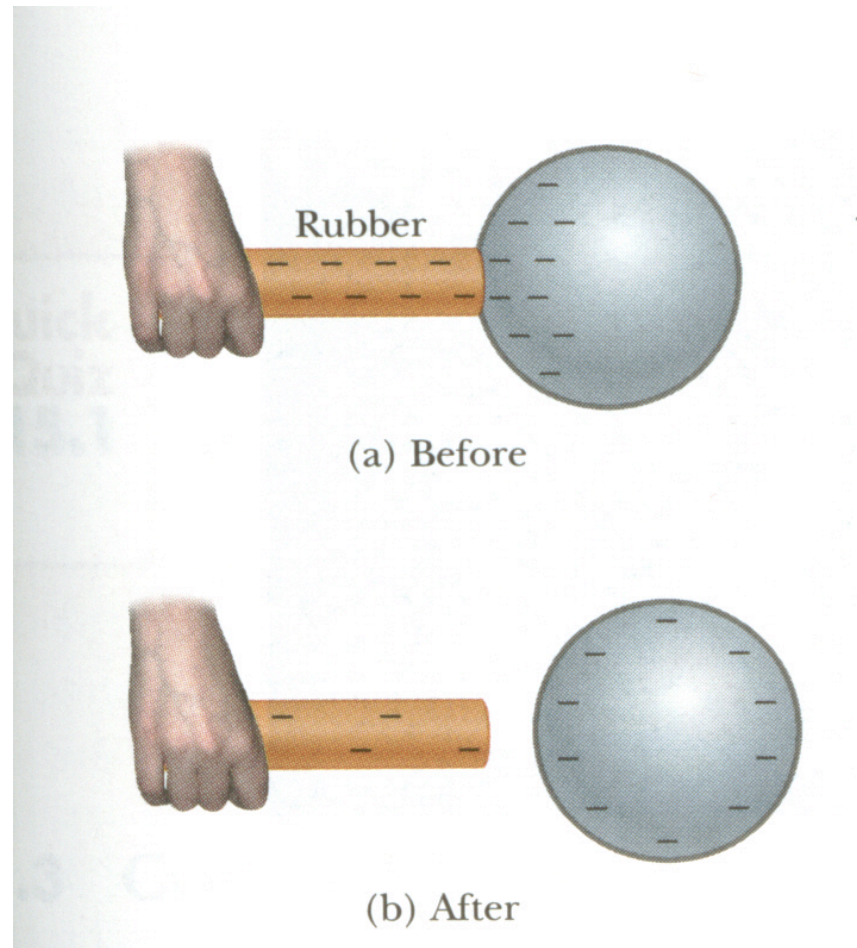

# Induced charge (Polarization)

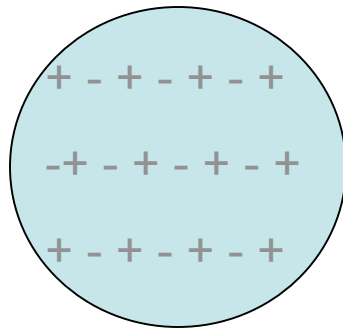

uncharged  
conductor



Attractive Force

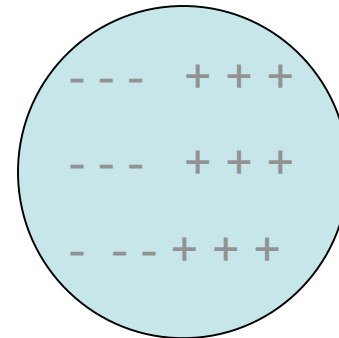

induced charge

# Charging by induction (polarization)

Ground - sink for electric charge

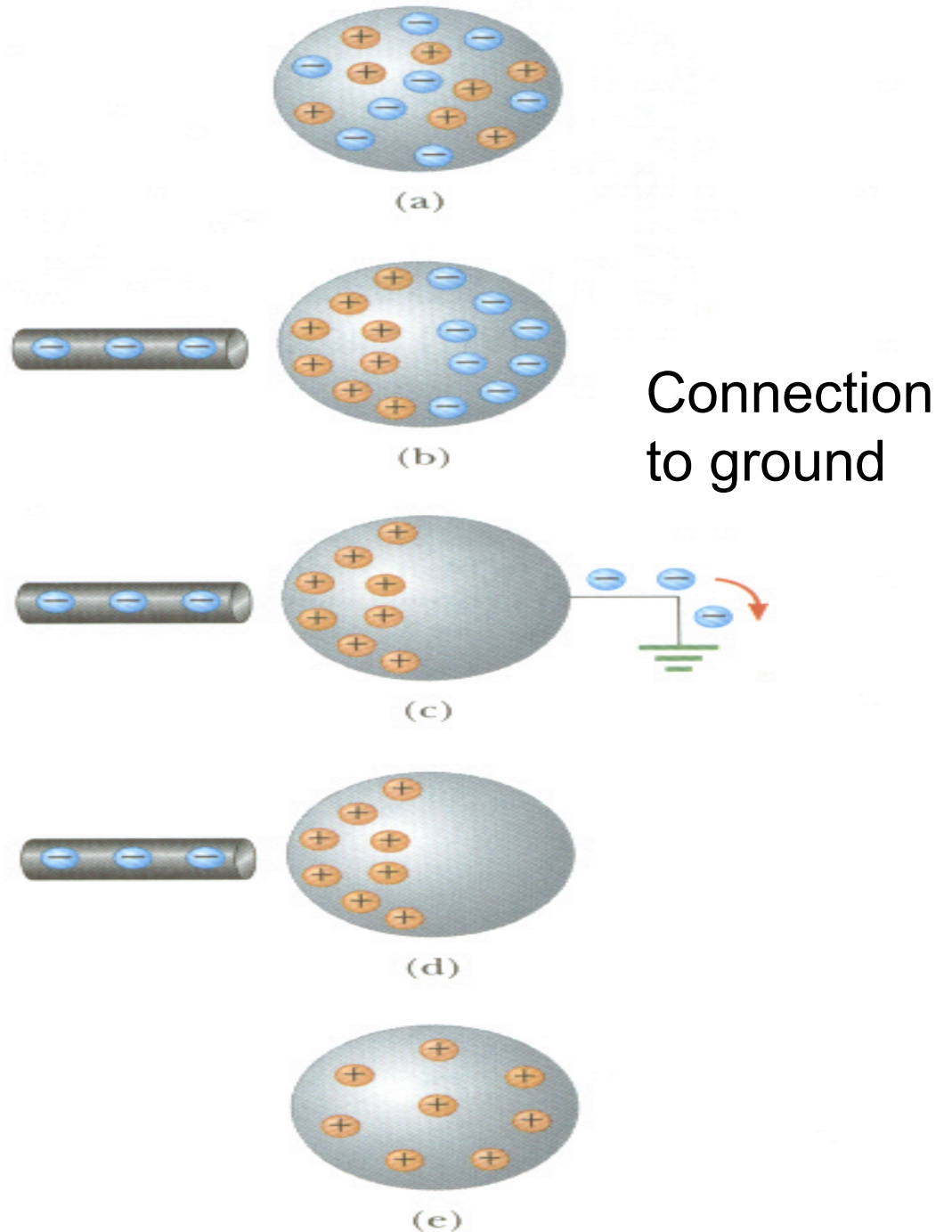

# Charging – Van de Graaf Generator

Spark- charge  
conduction due to  
ionization of atoms.

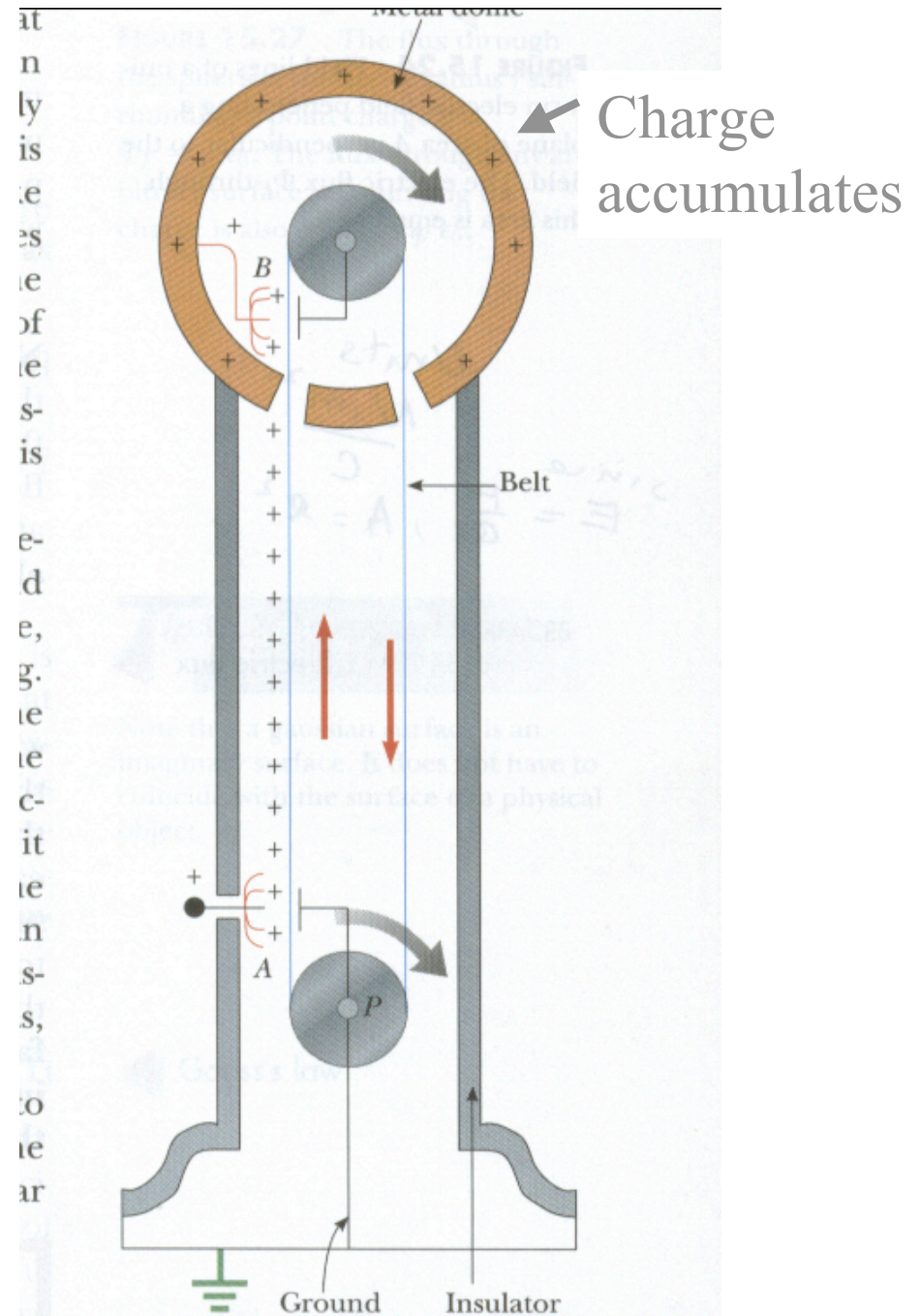

**FIGURE 15.23** A diagram of a Van de Graaff generator. Charge is trans

# Chapter 15.2

## Electric Forces

### Coulomb's Law

1. Force between two point charges
2. Superposition of forces from several point charges.

# Magnitude of charge

- Units of charge- Coulomb , C
- Charge on electron - e
- $e = 1.60 \times 10^{-19} \text{ C}$

# Point Charges

Point charge- charge localized at a point in space is an idealized object

Spherical charge distributions act as point charges with charge at the center

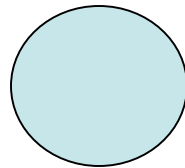

$q_1$

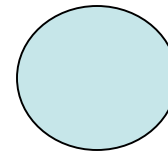

$q_2$

Small objects far away from each other act as point charges. Two charged pennies one mile apart

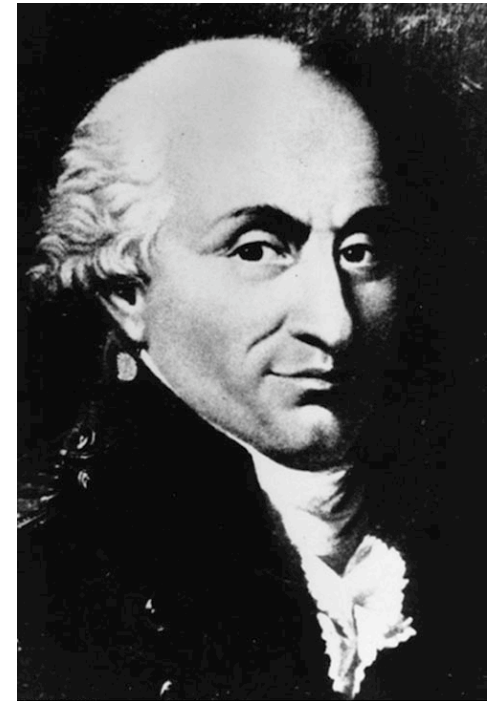
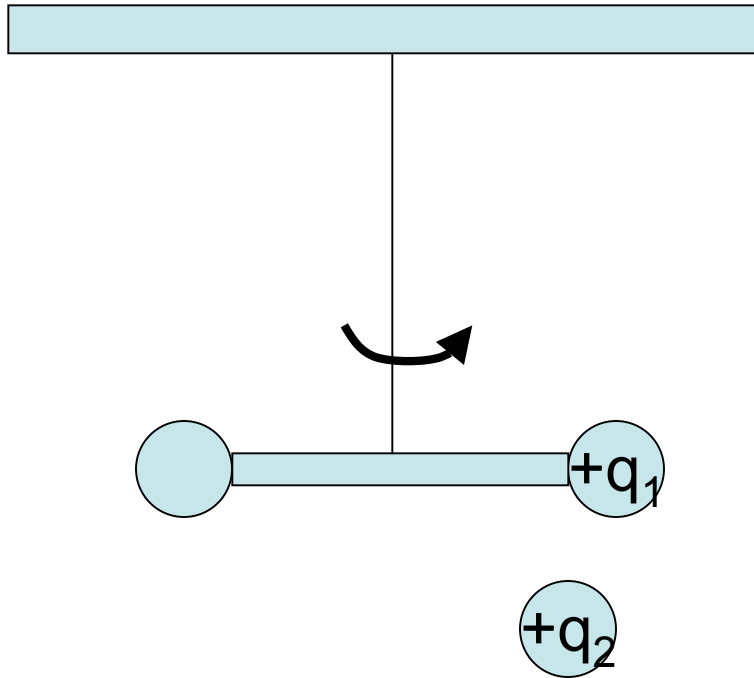

© 2003 Thomson - Brooks Cole

Measured the force between charges

Charles Coulomb  
1724-1806



# Torsion Balance

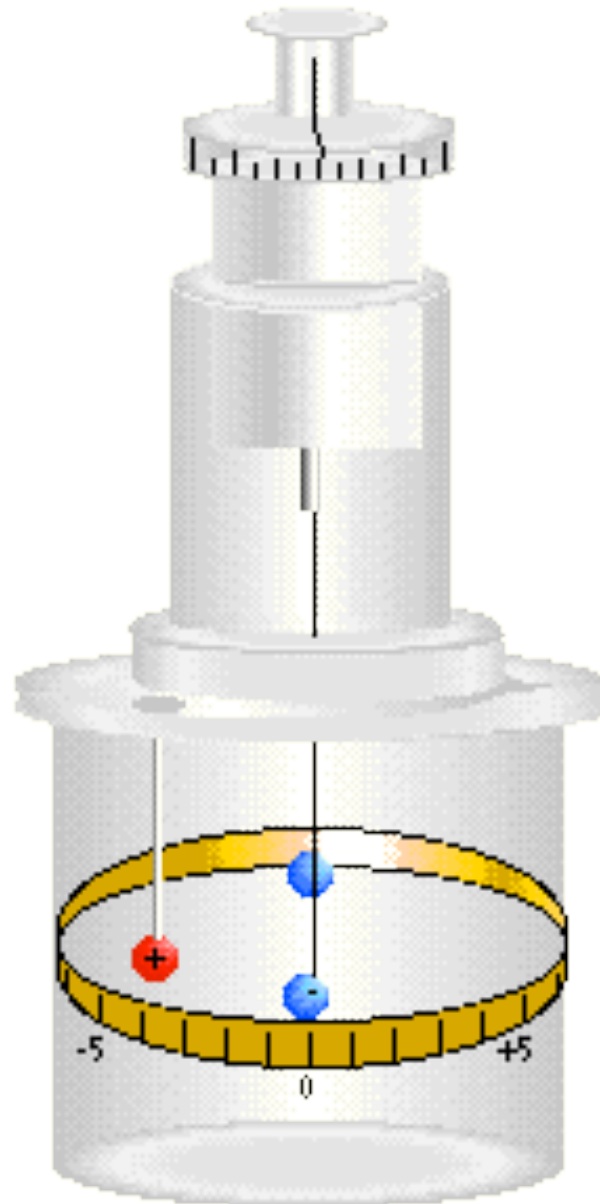

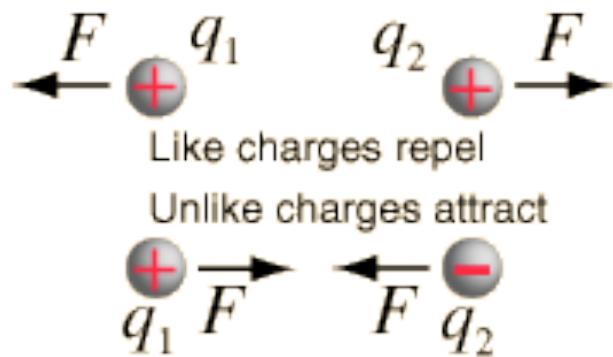

$$F = \frac{kq_1q_2}{r^2} = \frac{q_1q_2}{4\pi\epsilon_0 r^2} \quad \text{Coulomb's Law}$$

$$k = \frac{1}{4\pi\epsilon_0} \approx 9 \times 10^9 \text{ N} \cdot \text{m}^2/\text{C}^2 = \text{Coulomb's constant}$$

# Force between Charges

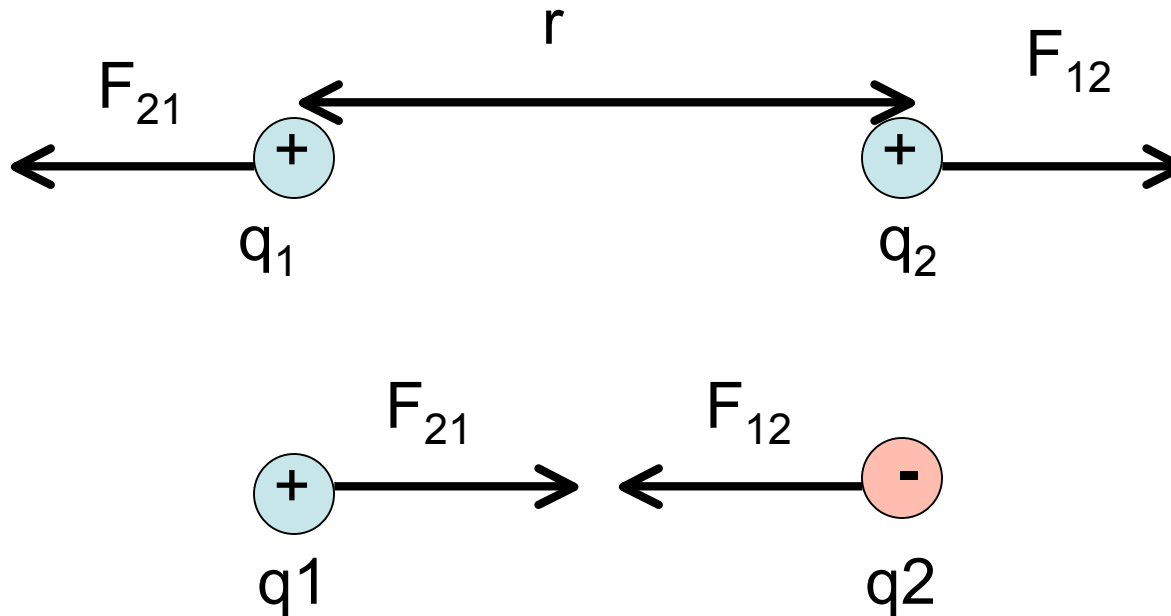

Magnitude of  $F$

proportional to product of charges  $q_1 q_2$

Inversely proportional to distance between charges,  $r$ , squared

Direction of  $F$

along line between charges.

Repulsive for like charges, Attractive for unlike charges

# Coulomb's Law

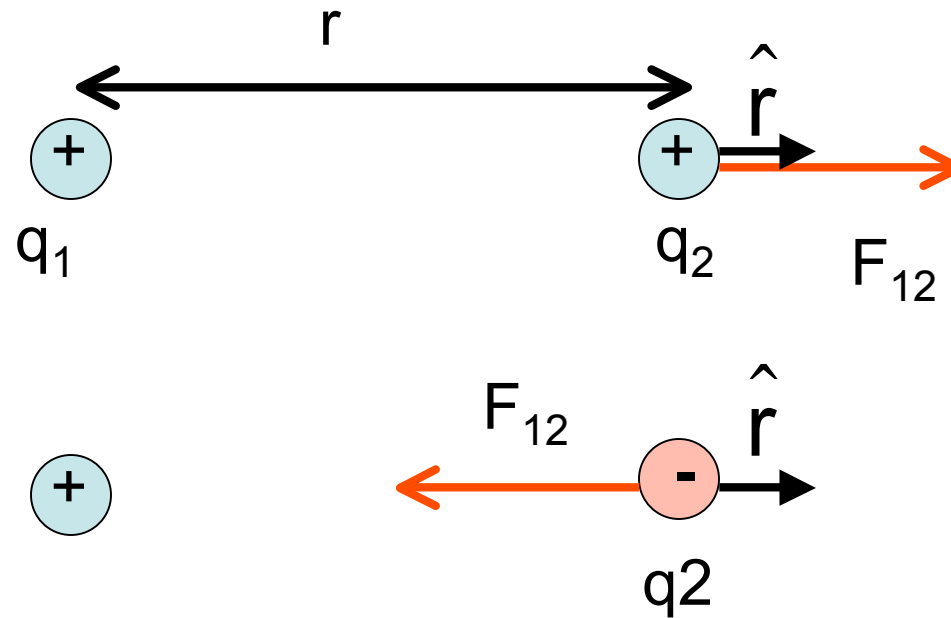

vector form

$$\vec{F}_{ij} = \frac{k_e q_i q_j}{r^2} \hat{r}$$

$\hat{r}$  a vector between charges with unit length.

$q_i q_j > 0$   $F$  is repulsive

$q_i q_j < 0$   $F$  is attractive

# Coulomb's Law

magnitude of force between 2 point charges or 2 spherical distributions of charge

$$|F| = k_e \frac{|q_1||q_2|}{r^2}$$

$$k_e = 8.99 \times 10^9 \text{ Nm}^2/\text{C}^2 \\ \sim 9 \times 10^9 \text{ Nm}^2/\text{C}^2$$

# 2 charges, each 1 Coulomb

$$F = \frac{(9 \times 10^9 \text{ N} \cdot \text{m}^2 / \text{C}^2)(1\text{C})(1\text{C})}{1\text{m}^2} = 9 \times 10^9 \text{ N}$$

$$F = (9 \times 10^9 \text{ N})(1\text{lb} / 4.45\text{N})(1 \text{ ton} / 2000 \text{ lb}) = 1.01 \text{ Million tons!}$$

# Magnitude of charge

How much charge is one mole of electrons?

$$\frac{\text{Coulombs}}{\text{mole}} = \frac{\text{electrons}}{\text{mole}} \times \frac{\text{Coulombs}}{\text{electron}}$$

$$\frac{(6 \times 10^{23} \text{ } e)}{\text{mole}} \frac{(1.6 \times 10^{-19} \text{ C})}{e}$$

$$= 9.6 \times 10^4 \text{ C / mole}$$

$$\approx 10^5 \text{ C / mole}$$

# Example

- Let's examine the amount of charge in a sphere of [copper](#) of volume one cubic centimeter.
- [Cu has one valence electron outside of closed shells in its atom, and that electron is free to move.](#)
- The density of metallic Cu =  $9 \text{ g/cm}^3$  and one mole of Cu = 63.5 grams so the cubic centimeter of Cu = 1/7th of a [mole](#) or about  $8.5 \times 10^{22}$  Cu atoms.
- [With one mobile electron per atom, and with the electron charge of  \$1.6 \times 10^{-19} \text{ C}\$ , so there are  \$\sim 13,600 \text{ C/cm}^3\$ .](#)
- Suppose we remove enough of the electrons from two spheres of Cu so that there is enough net positive charge on them to suspend one of them over the other. What fraction of the electron charge must we remove?
- [The force to lift one of the spheres of copper would be its weight, 0.088 N.](#)
- Radius of a  $1 \text{ cm}^3 = 0.62 \text{ cm}$ , separation = 2.48 cm Using Coulomb's law, this requires a charge of  $7.8 \times 10^{-8} \text{ Coulombs}$ .
- [This amounts to removing just one valence electron out of every  \$5.7 \times 10^{12}\$  from each copper sphere.](#)

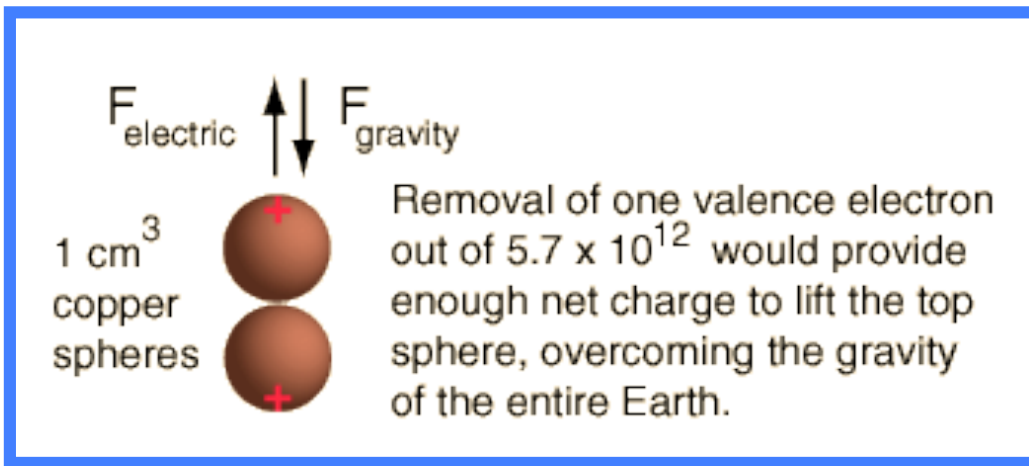



# Pith Ball

# Similarity with the gravitational force ( $1/r^2$ dependence)

$$F_G = G \frac{M_1 M_2}{r^2} \qquad G = 7 \times 10^{-11} \frac{Nm^2}{kg^2}$$

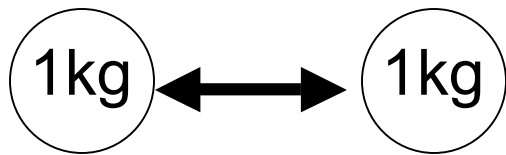

$r=1m$

$$F_G = 7 \times 10^{-11} \text{ N}$$

---

$$F_e = k_e \frac{q_1 q_2}{r^2} \qquad k_e = 9 \times 10^9 \frac{Nm^2}{C^2}$$

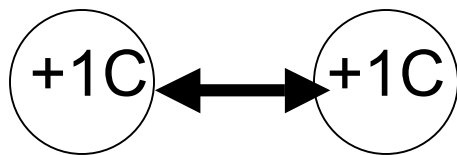

$r=1m$

$$F_e = 9 \times 10^9 \text{ N}$$

$10^{20}$  times more than  $F_G$

Two 0.2 g spheres each carrying charge +q are suspended from a 30 cm thread make an angle of  $5^\circ$  from the vertical direction. Find q.

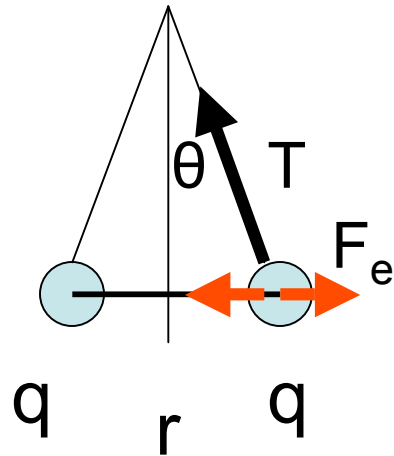

Electrical Force

$$F_e = \frac{kq^2}{r^2} = T \sin \theta$$

relations  $mg = T \cos \theta$       $r = 2L \sin \theta$

solve  $\frac{kq^2}{(2L \sin \theta)^2} = mg \tan \theta$

$$q = \sqrt{\frac{mg \tan \theta}{k}} (2L \sin \theta) = \sqrt{\frac{(0.2 \times 10^{-3})(9.8) \tan(5)}{9 \times 10^9}} [2(0.3)(\sin(5))] = 7.2 \times 10^{-9} \text{ C}$$

A Small Charge

Force between several point charges  
Superposition principle- Forces Add  
Independently

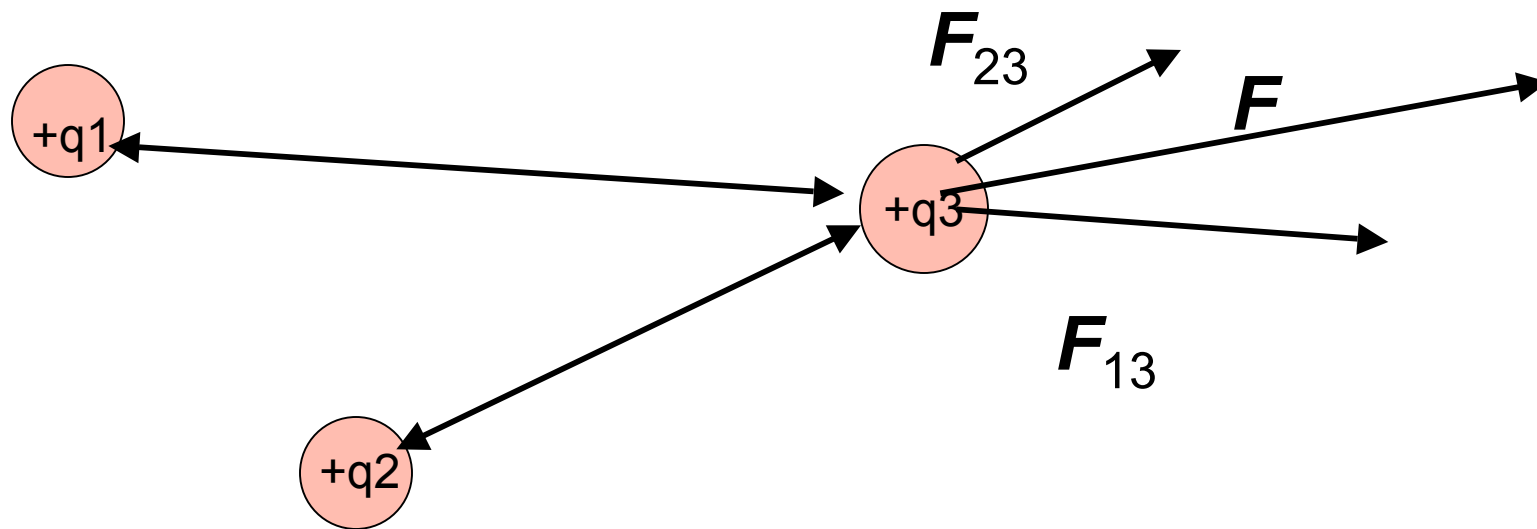

Force acting on  $q_3$        $\vec{F} = \vec{F}_{13} + \vec{F}_{23}$

Net force = vector sum of forces

Suppose you had a charge  $q$  at the center of a square having Charges of  $q$  at each corner. What is the force on the charge In the center?

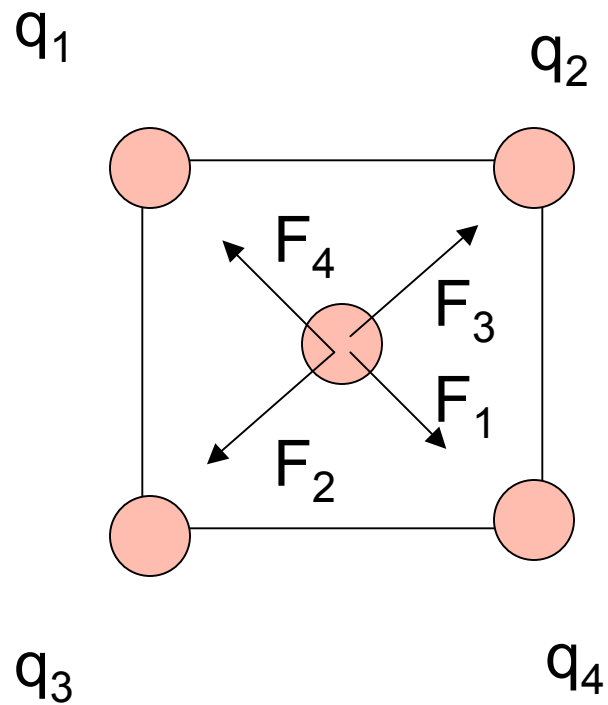

$$\vec{F}_1 + \vec{F}_4 = 0$$

$$\vec{F}_2 + \vec{F}_3 = 0$$

$$\sum \vec{F} = 0$$

Two charges are in a line.  $q_1 = -1\mu\text{C}$ ,  $q_2 = 2\mu\text{C}$  Is there a position along the line through the centers where the force on a + charge,  $q_3$  is zero? Is it in the A, B or C region?

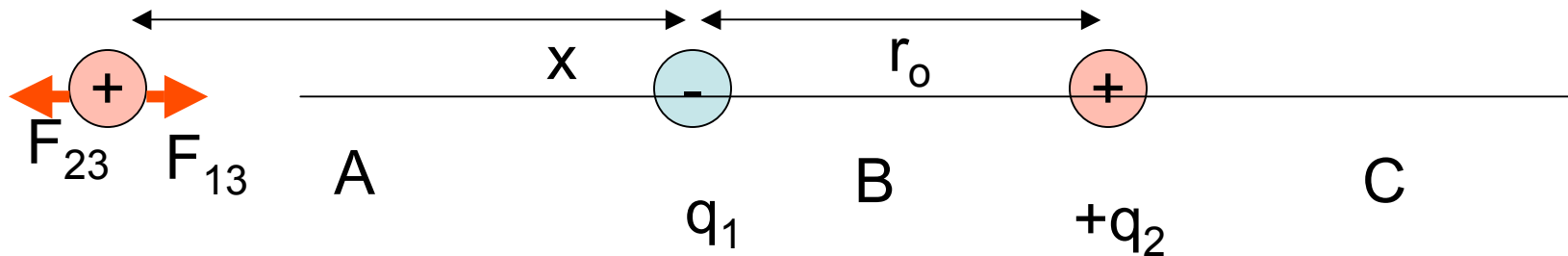

It must be in the A region. The force from the smaller -charge can be increased by a smaller distance

$$|F_{13}| = |F_{23}|$$

$$\frac{k_e |q_1| |q_3|}{x^2} = \frac{k_e |q_2| |q_3|}{(r_0 + x)^2}$$

$$(r_0 + x)^2 |q_1| = x^2 |q_2|$$

$$(r_0 + x) \sqrt{|q_1|} = x \sqrt{|q_2|}$$

$$x = \frac{\sqrt{|q_1|}}{\sqrt{|q_2|} - \sqrt{|q_1|}} r_0 = \frac{\sqrt{1}}{\sqrt{2} - \sqrt{1}} r_0 = 2.41 r_0$$

$$r_0 + x = 3.41 r_0$$

Three charges are placed at the corners of a square with the length of each side = 2.0 cm. Find the force on  $q_3$ .  $q_3 = -2 \times 10^{-6} \text{ C}$   $q_1 = q_2 = 1 \times 10^{-6} \text{ C}$

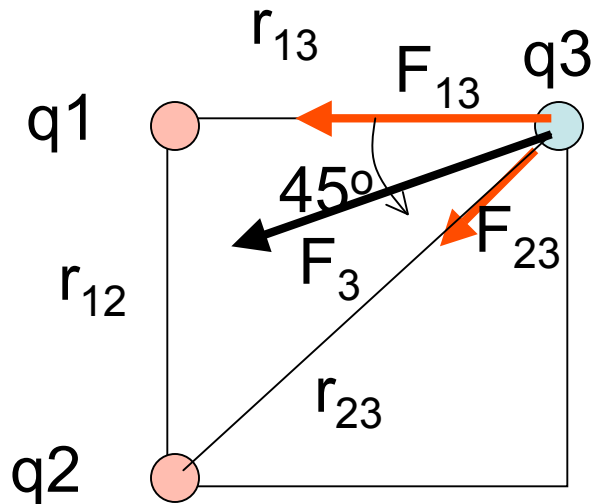

Forces acting on  $q_3$

$$F_{13} =$$

$$F_{23} =$$

$$F_3 =$$

$$r_{23}^2 = r_{13}^2 + r_{12}^2$$

$$r_{23}^2 = 2r_{13}^2$$

$$r_{23} = \sqrt{2}r_{13}$$

$$F_{13} = \frac{k_e q_1 q_3}{r_{13}^2} = \frac{9 \times 10^9 (10^{-6})(2 \times 10^{-6})}{(2 \times 10^{-2})^2} = 45 \text{ N}$$

$$F_{23} = \frac{k_e q_2 q_3}{r_{23}^2} = \frac{9 \times 10^9 (10^{-6})(2 \times 10^{-6})}{2(2 \times 10^{-2})^2} = 22.5 \text{ N}$$

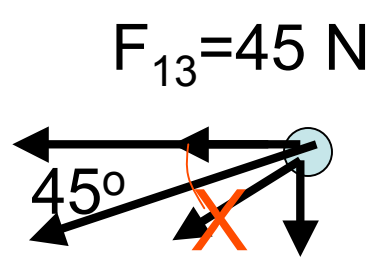

Solve

Find x and y components.

Consider only the relative magnitudes

Ignore the minus sign

$$F_3 \quad F_{23} = 22.5 \text{ N}$$

$$F_3 = \sqrt{F_{3x}^2 + F_{3y}^2}$$

$$F_{3x} = 45 + 22.5(\cos 45) = 61 \text{ N}$$

$$F_{3y} = 22.5(\sin 45) = 16 \text{ N}$$

$$F_3 = \sqrt{61^2 + 16^2} = 63 \text{ N}$$



### Example 15.3 Where is the resultant force zero?

Two charges are in a line

$q_1 = 15\mu\text{C}$  ,  $q_2 = 6.0\mu\text{C}$  a negative charge  $q_3$  must be placed in between them at a position where the net force is zero. Where should it be placed?

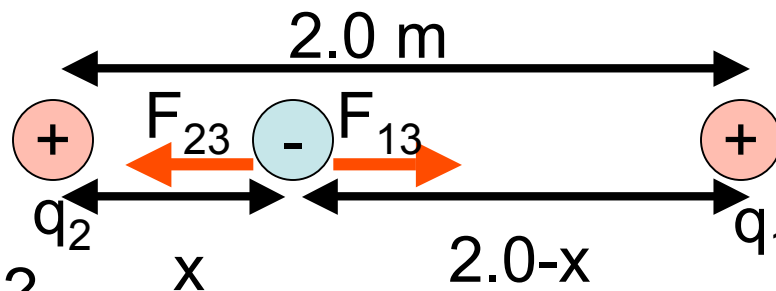

closer to  $q_1$  or  $q_2$  ?

Magnitudes of forces are equal

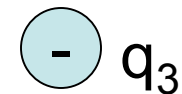

$$\frac{F_{13}}{kq_1q_3} = \frac{F_{23}}{kq_2q_3}$$

$$\frac{q_1}{(2-x)^2} = \frac{q_2}{x^2}$$

$$\frac{x^2}{(2-x)^2} = \frac{q_2}{q_1}$$

$$\frac{x}{2-x} = \sqrt{\frac{q_2}{q_1}} = \sqrt{\frac{6}{15}} = 0.63 = \alpha$$

$$x = \frac{2\alpha}{1+\alpha} = \frac{2(0.63)}{1+0.63} = 0.77 \text{ m}$$

$$2-x = 2 - 0.77 = 1.23 \text{ m}$$