

PHYSICS 1B – Fall 2007



Electricity & Magnetism



Professor Brian Keating
SERF Building, Room 333

Monday 10/29 Lecture

Quiz 2 Friday 11/2 10am: Same rules as Quiz 1
Write your 3 digit number and PID number on Quiz
Scantron

Today: Capacitors in Series/Parallel

Wednesday: we'll do the HW via clickers, 6 questions from
Chapter 16.

Capacitor combinations

Capacitors connected in series
and parallel

Electrical circuit elements

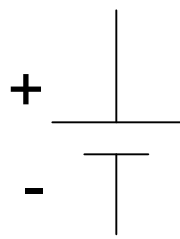

Voltage source



resistor

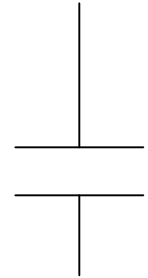

capacitor

Circuit diagram

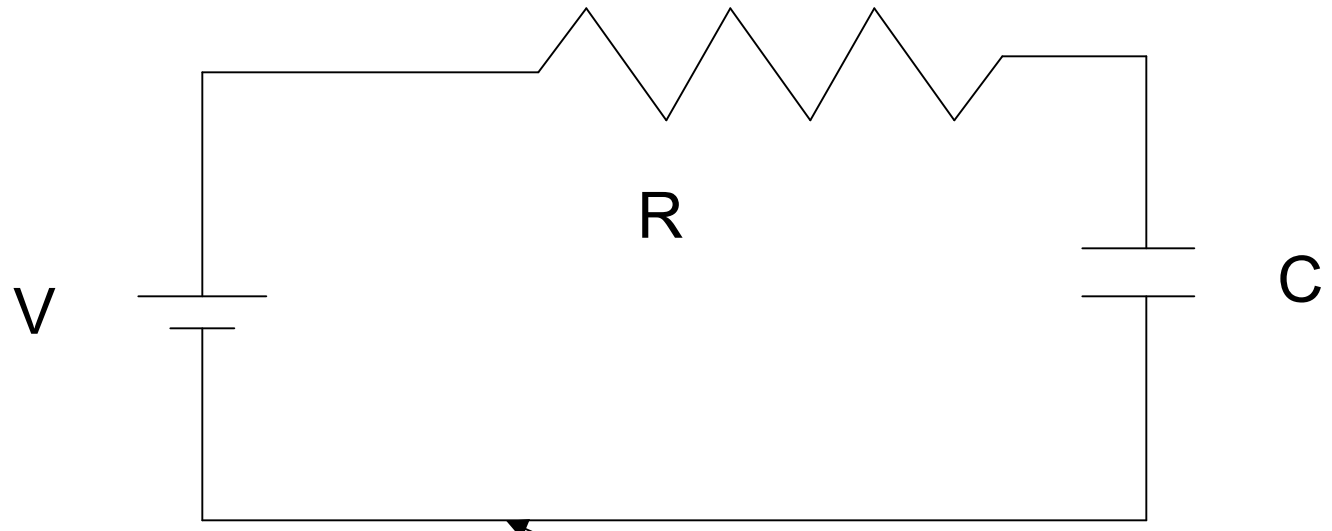

Conductor

one capacitor

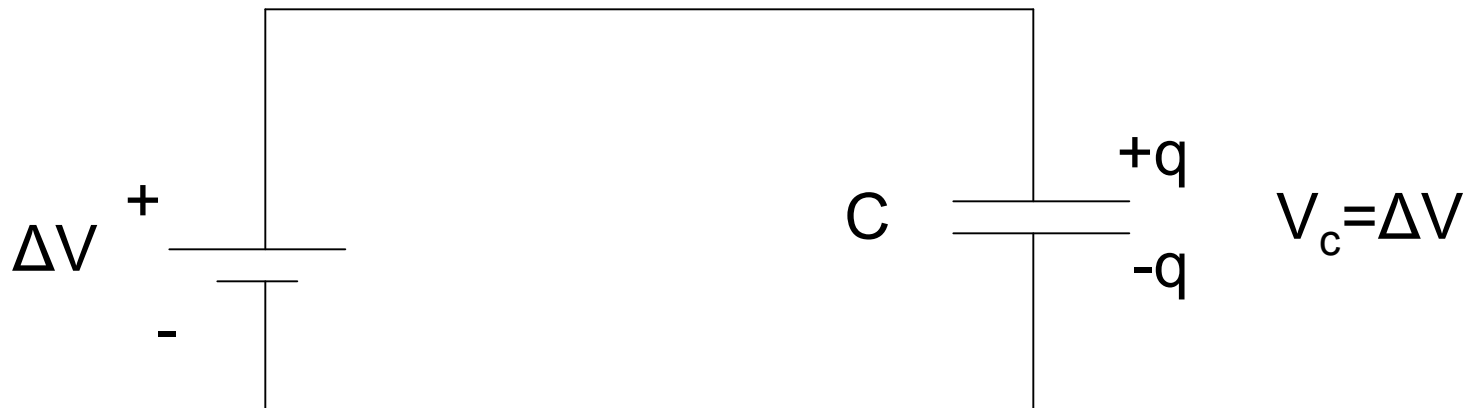

$$C = \frac{q}{\Delta V}$$

Two Capacitors in Parallel

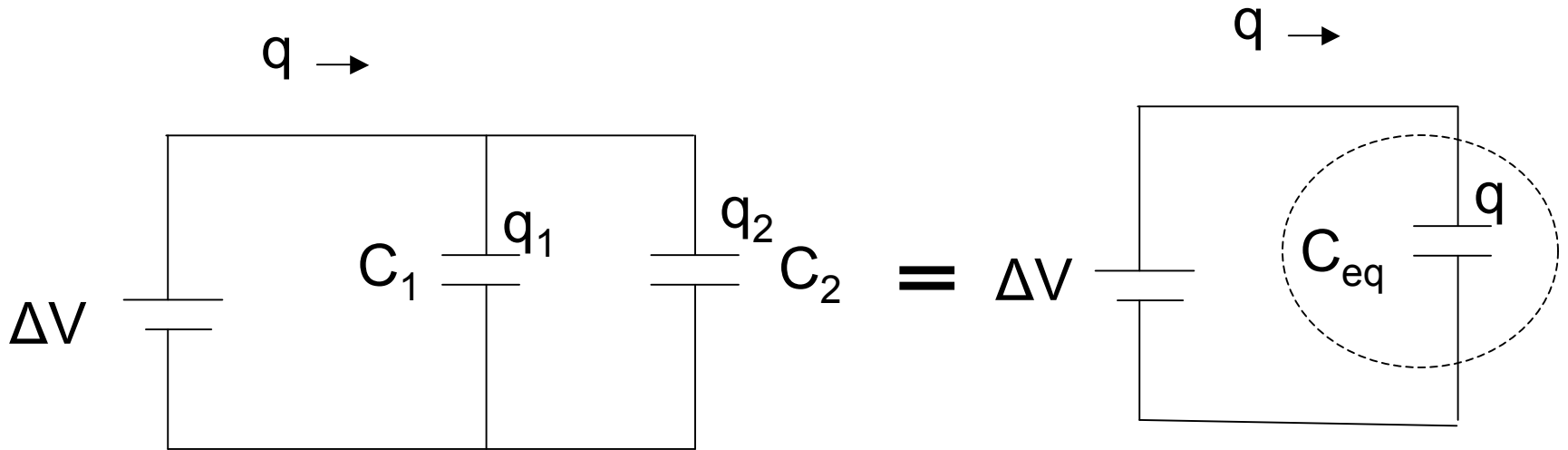

$$C_{eq} = \frac{q}{\Delta V}$$

equivalent
capacitance

What single capacitor has the same properties as two capacitors in parallel?

Two Parallel Capacitors

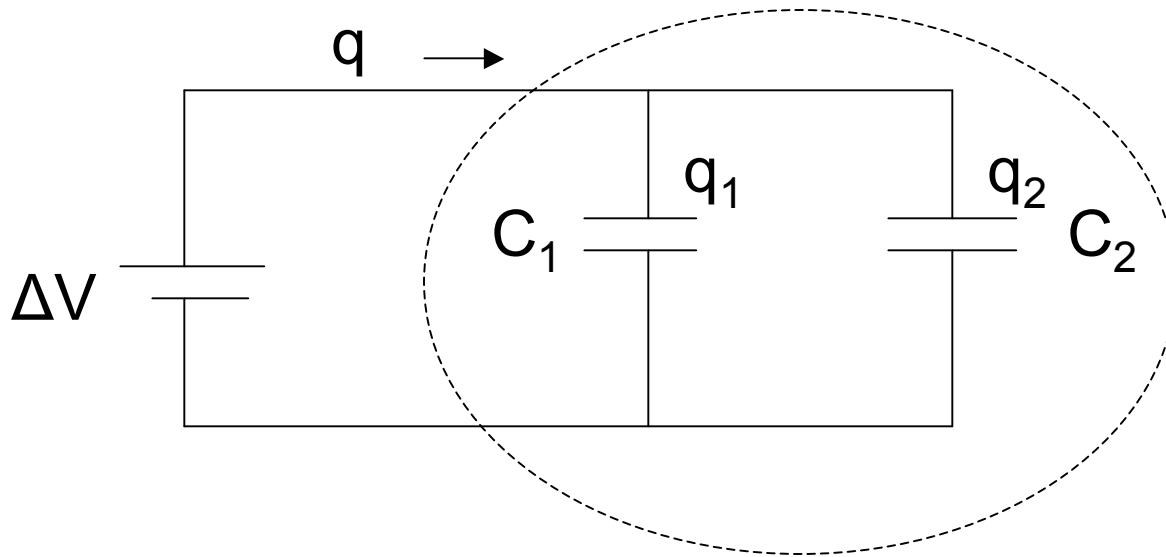

equivalent
capacitance

$$C_{eq} = \frac{q}{\Delta V}$$

$$\Delta V = \Delta V_1 = \Delta V_2$$

$$q = q_1 + q_2 = C_1 \Delta V + C_2 \Delta V$$

$$C_{eq} = \frac{q}{\Delta V} = \frac{C_1 \Delta V + C_2 \Delta V}{\Delta V}$$

$$C_{eq} = C_1 + C_2$$

Parallel Capacitors

For N capacitors in parallel

$$C_{eq} = C_1 + C_2 + \dots + C_N$$

C_{eq} is the sum of capacitances

Like a larger capacitor, larger area

Find the equivalent capacitance

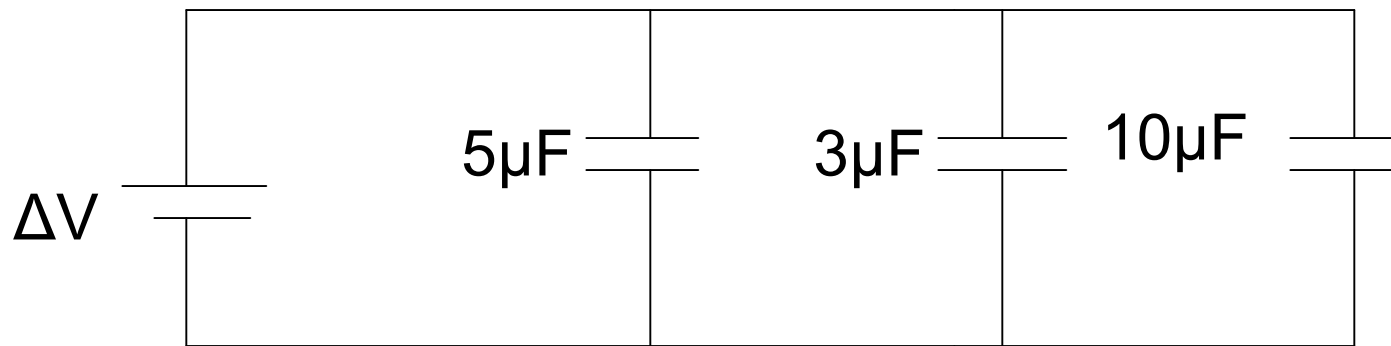

- $C_{eq} =$ A. 15 μF
 $C_{eq} =$ B. 17 μF
 $C_{eq} =$ C. 18 μF
D. 20 μF



Find the equivalent capacitance

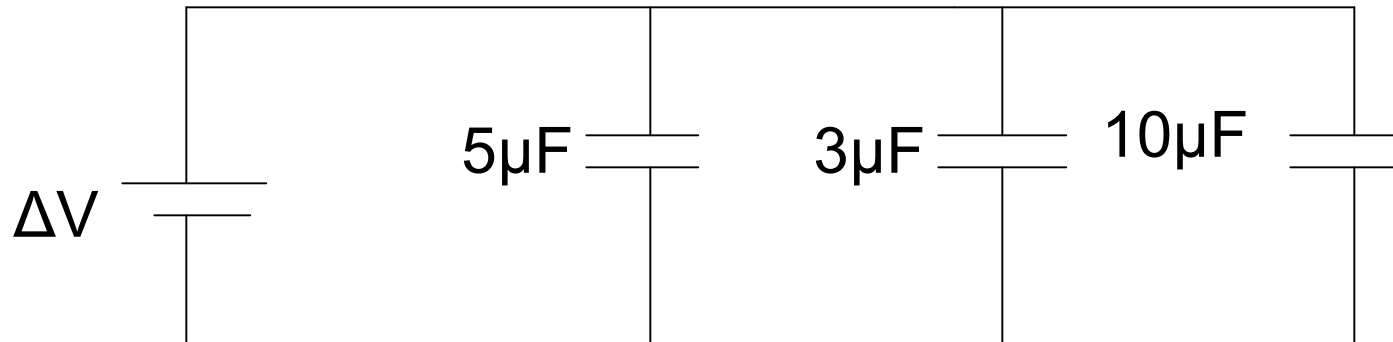

$$C_{eq} = C_1 + C_2 + C_3$$

$$C_{eq} = 5 + 3 + 10 = 18\mu\text{F}$$

Two Capacitors in Series

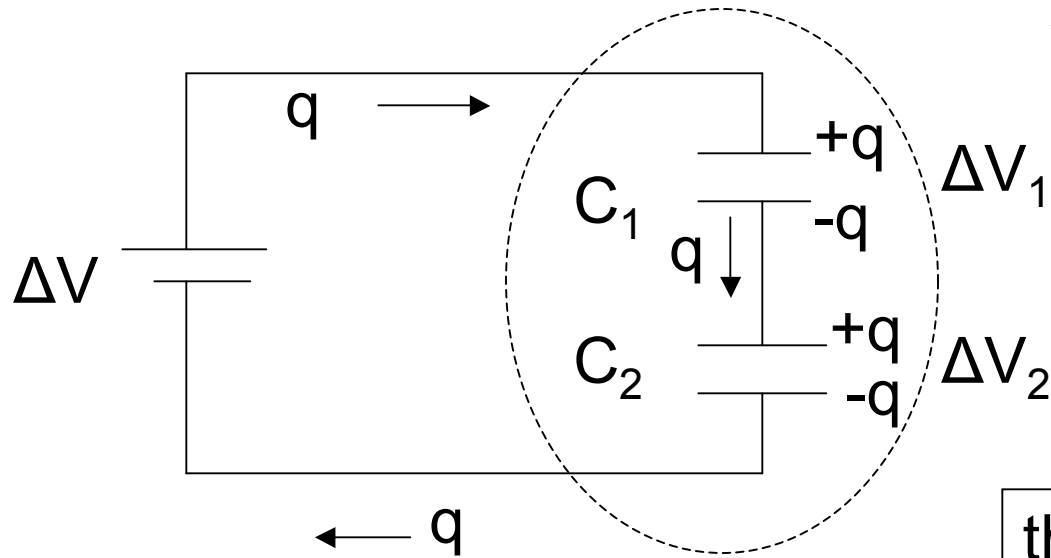

What is the equivalent capacitance?

$$C_{eq} = \frac{q}{\Delta V}$$

the charge on both capacitors in series is q

Two Capacitors in Series

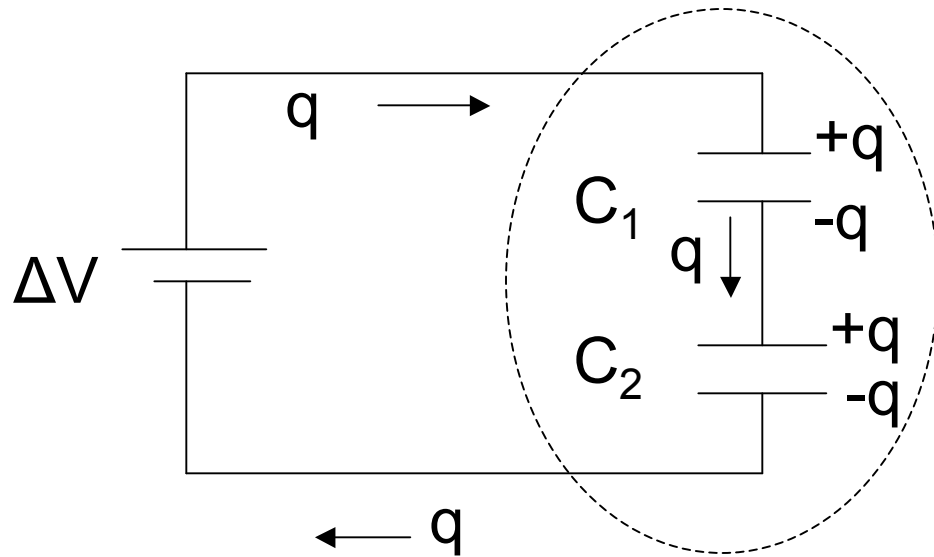

$$C_{eq} = \frac{q}{\Delta V}$$

$$q = q_1 = q_2$$

$$\Delta V = \Delta V_1 + \Delta V_2 = \frac{q}{C_1} + \frac{q}{C_2}$$

$$\frac{1}{C_{eq}} = \frac{\Delta V}{q} = \frac{1}{q} \left(\frac{q}{C_1} + \frac{q}{C_2} \right)$$

$$\frac{1}{C_{eq}} = \frac{1}{C_1} + \frac{1}{C_2}$$

For N capacitors in series

$$\frac{1}{C_{eq}} = \frac{1}{C_1} + \frac{1}{C_2} + \dots + \frac{1}{C_N}$$

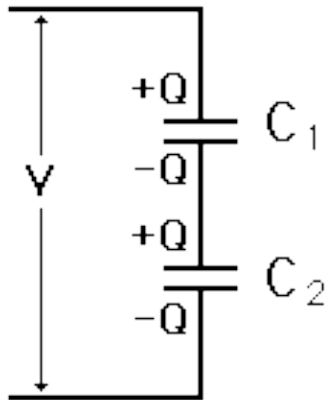

Capacitors in series

C_{eq} is smaller than the smallest capacitance. You store less charge on series capacitors than you would on either one of them alone with the same voltage!

Physical Argument

Take a parallel plate capacitor and place a thin metal plate with the same area in the middle of the gap.

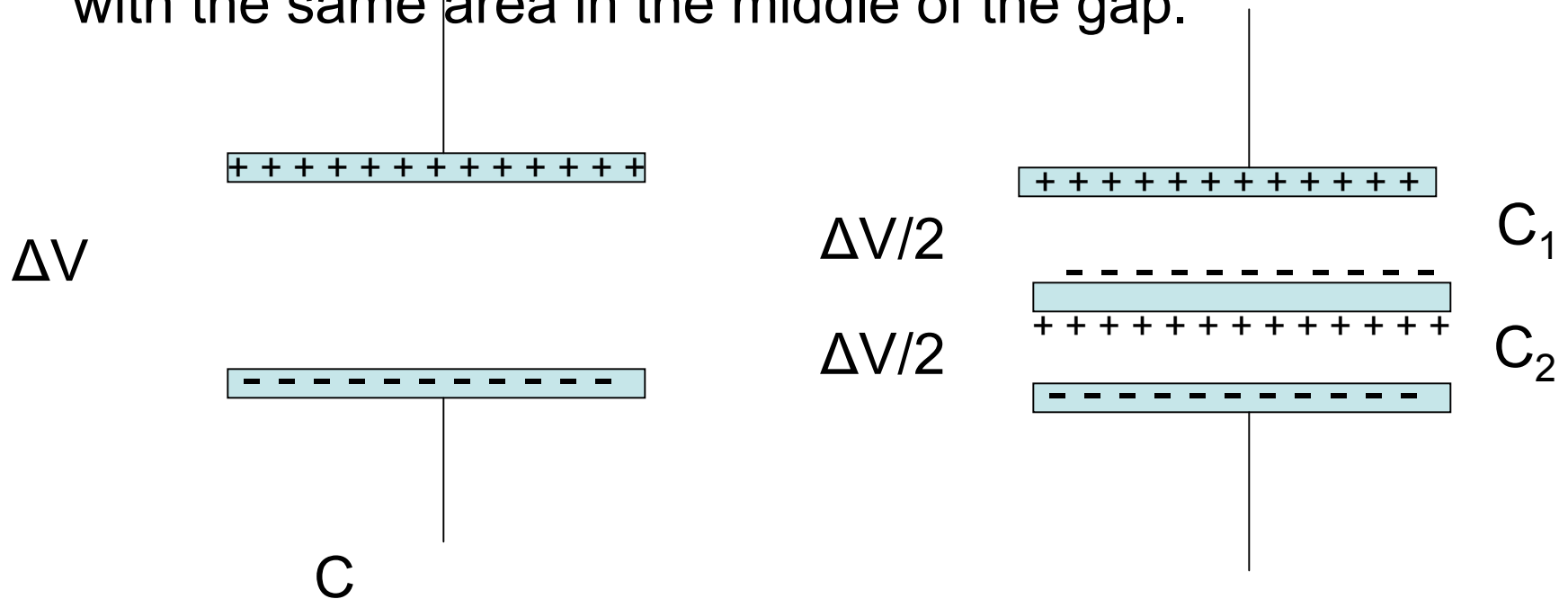

the component capacitances
are larger than the total

$$C_1 = C_2 = 2C$$

$$C_{eq} = C$$

The equivalent capacitance is less than the
component capacitances

$$C_{eq} < C_1 \text{ or } C_2$$

Find the equivalent capacitance

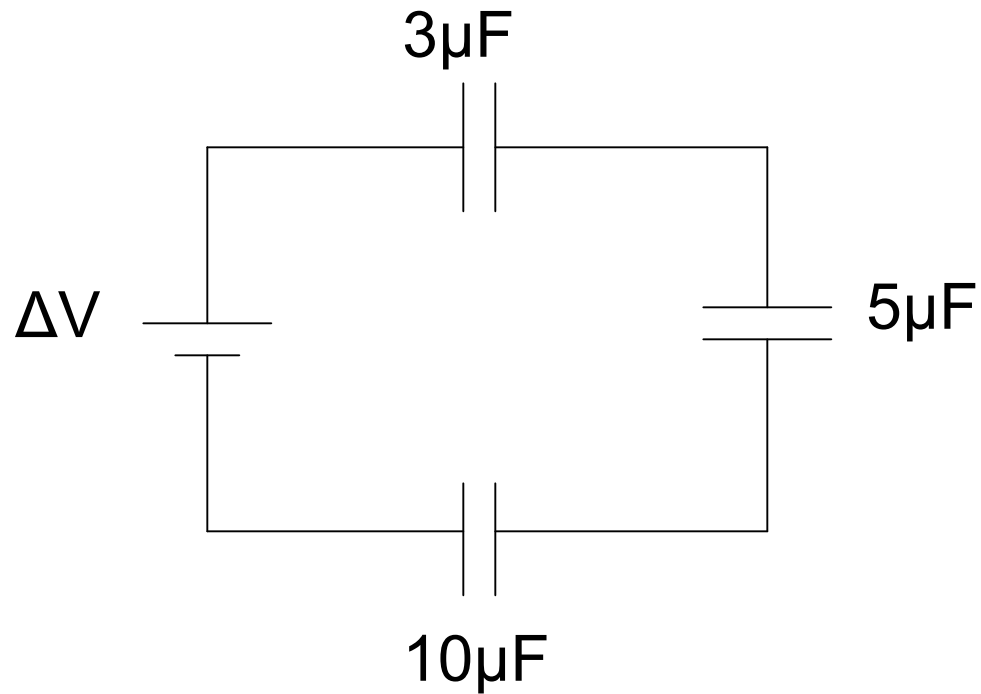

$$\frac{1}{C_{eq}} = \frac{1}{C_1} + \frac{1}{C_2} + \frac{1}{C_3} = \frac{1}{5} + \frac{1}{3} + \frac{1}{10} = 0.633$$

$$C_{eq} = 1.58\mu\text{F}$$

34. Find the equivalent capacitance.

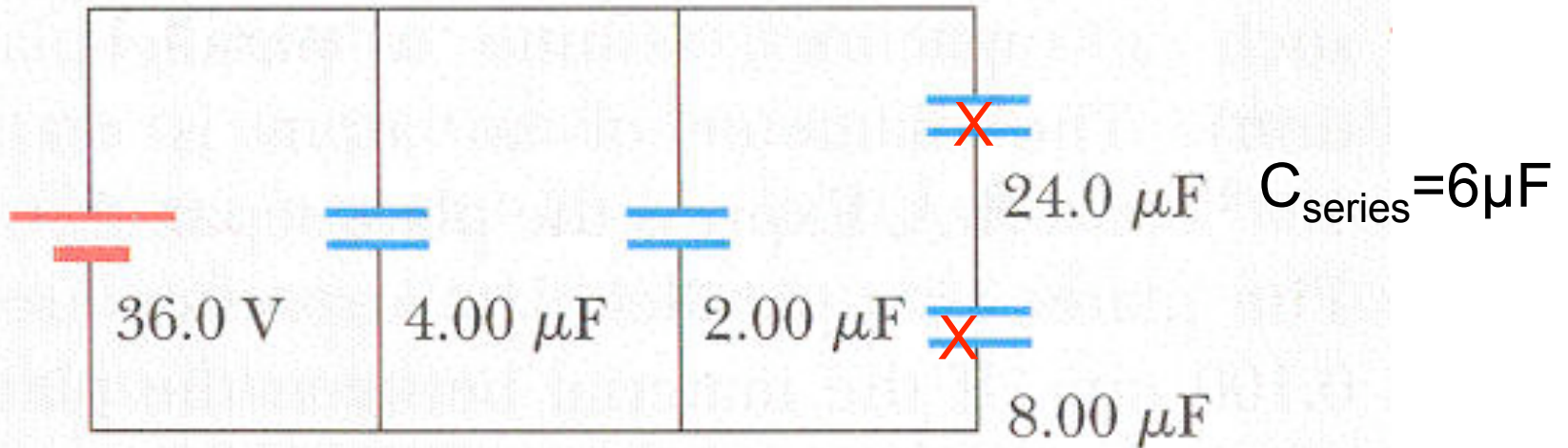

FIGURE P16.34

$$\frac{1}{C_{\text{series}}} = \frac{1}{24} + \frac{1}{8} = \frac{4}{24} = \frac{1}{6}$$

$$C_{\text{eq}} = 4.00 + 2.00 + 6.00 = 12.00 \mu\text{F}$$

34. Find the charge on each capacitor.

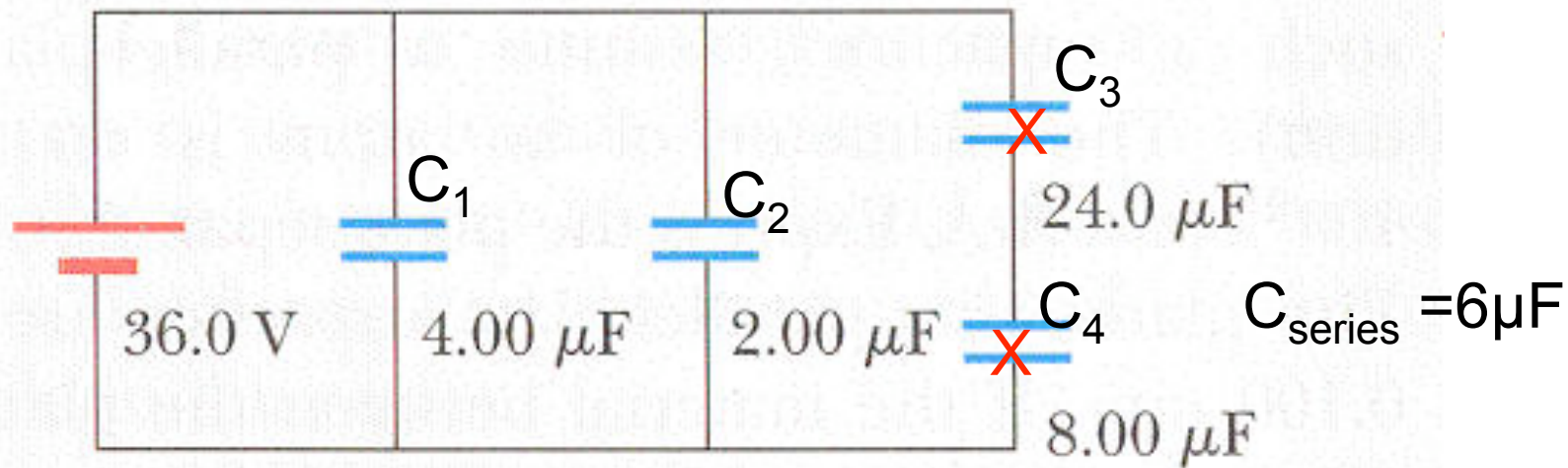

FIGURE P16.34

$$q = C\Delta V$$

$$q_1 = C_1 \Delta V = 4 \times 10^{-6} (36) = 1.44 \times 10^{-4} \text{ C}$$

$$q_2 = C_2 \Delta V = 2 \times 10^{-6} (36) = 0.72 \times 10^{-4} \text{ C}$$

$$q_3 = q_4 = C_{\text{series}} \Delta V = 6 \times 10^{-6} (36) = 2.16 \times 10^{-4} \text{ C}$$

34. Find the voltage drop across each capacitor.

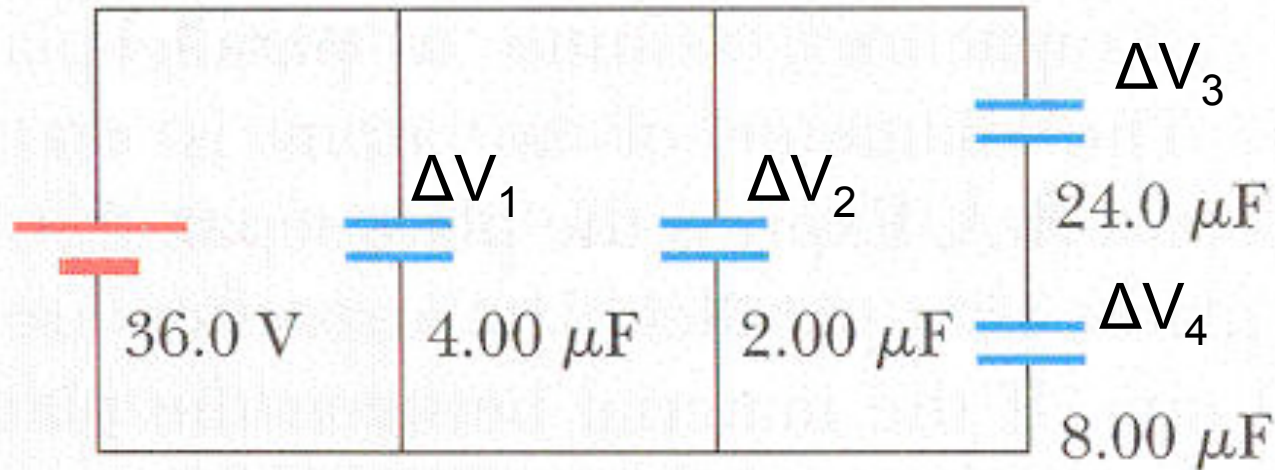

FIGURE P16.34

$$\Delta V = \frac{q}{C}$$

$$\Delta V_1 = \Delta V_2 = 36V$$

$$\Delta V_3 = \frac{q}{C_3} = \frac{2.16 \times 10^{-4}}{24 \times 10^{-6}} = 9.0V$$

$$\Delta V_4 = \frac{q}{C_4} = \frac{2.16 \times 10^{-4}}{8 \times 10^{-6}} = 27V$$

series capacitors
The larger C has
the smaller
voltage drop

42. Find the equivalent capacitance between a and b.

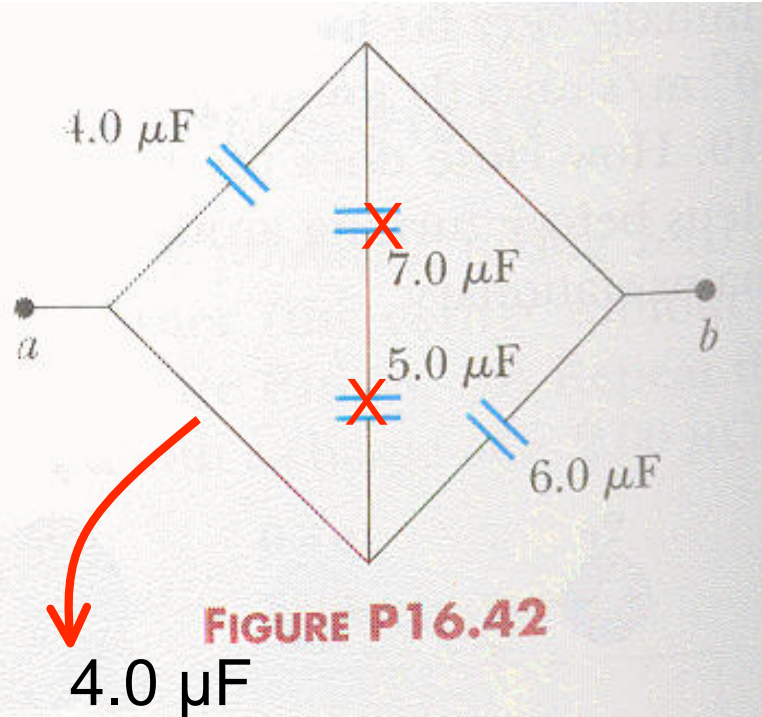

$$\frac{1}{C_{\text{ser}}} = \frac{1}{7} + \frac{1}{5} = \frac{1}{35/12}$$

$$C_{\text{ser}} = 2.9 \mu\text{F}$$

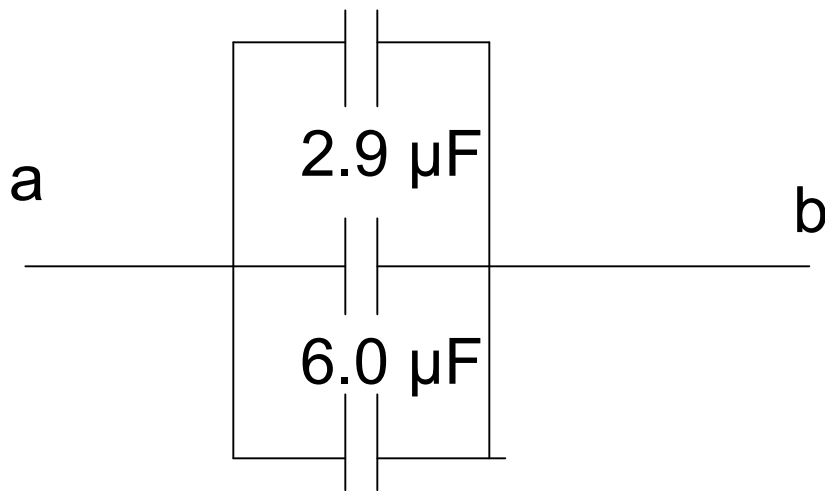

$$C_{\text{eq}} = 4.0 + 2.9 + 6.0$$

$$= 12.9 \mu\text{F}$$

Two identical capacitors. charge one capacitor at 10 V , disconnect, connect the charged capacitor to the uncharged capacitor. What is the voltage drop across the each capacitor?

One way to do this problem

q is constant but divided between the two capacitors

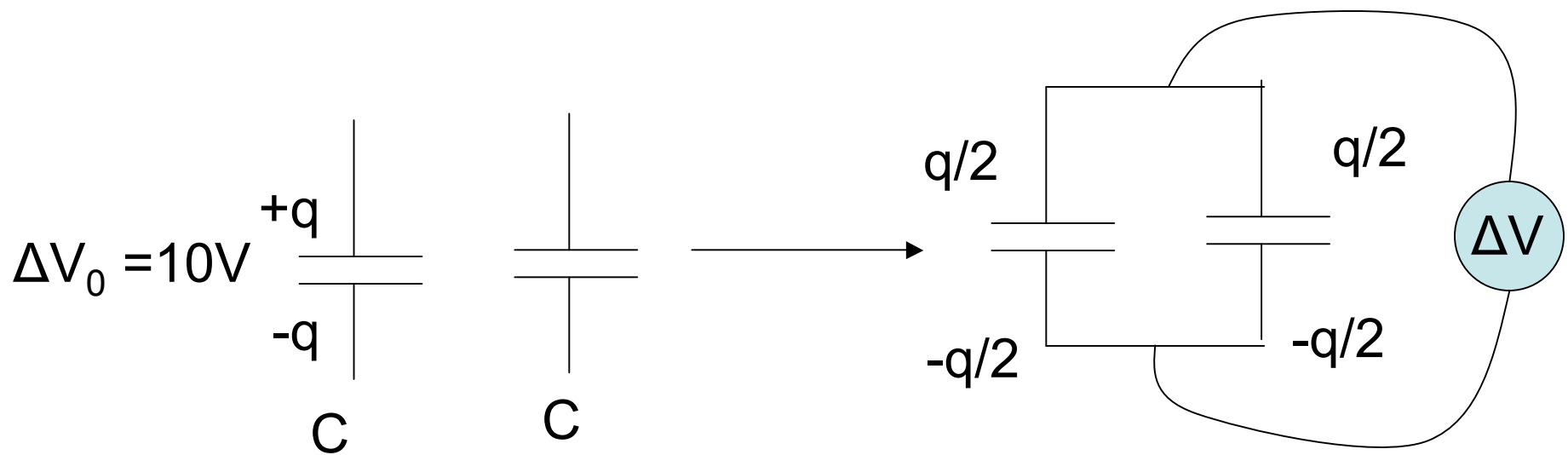

the charge on each capacitor is reduced by 2 fold
 thus the voltage across each capacitor is reduced
 by 2fold

$$\Delta V = \frac{\Delta V_0}{2}$$

charge one capacitor at 10 V , disconnect, connect the charged capacitor to the uncharged capacitor. What is the voltage drop across the each capacitor?

Another way to do this problem

q is constant but is placed on an equivalent capacitor

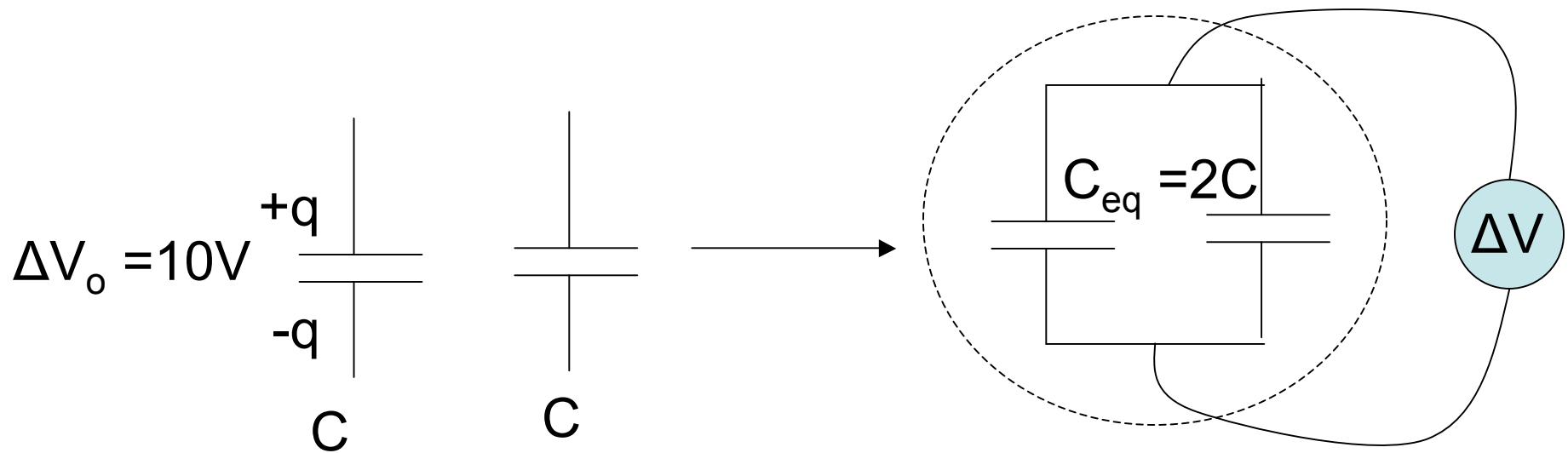

The voltage is reduced by 2 fold

$$\Delta V = \frac{q}{C_{eq}} = \frac{q}{2C} = \frac{\Delta V_o}{2}$$

PHYSICS 1B – Fall 2007



Electricity & Magnetism



Professor Brian Keating
SERF Building, Room 333

Two Capacitors in Parallel

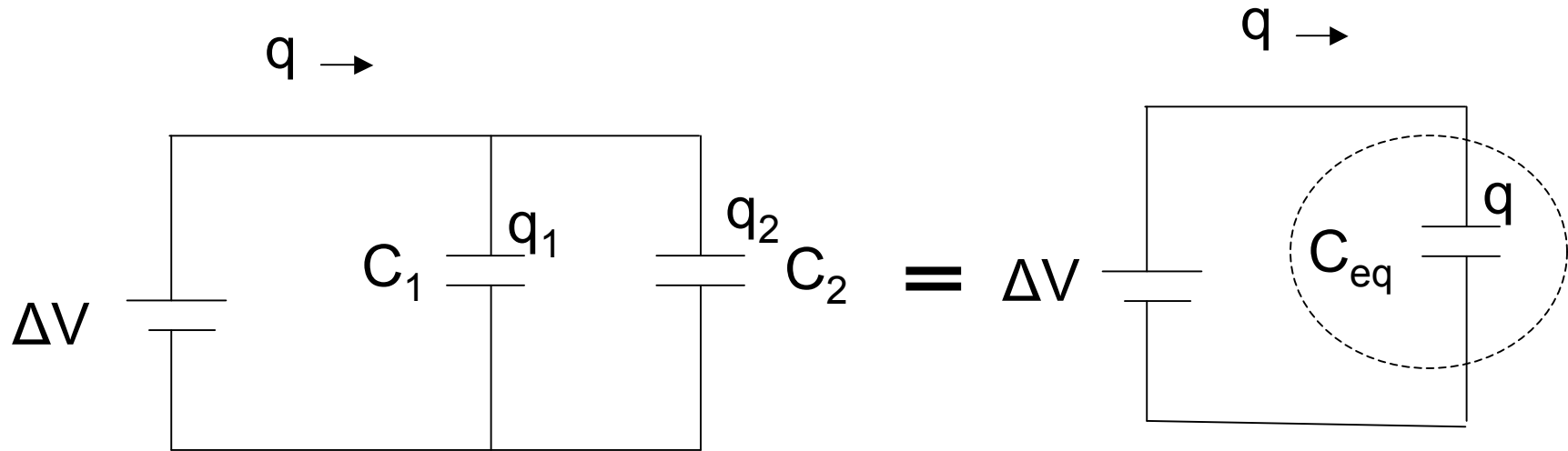

$$C_{eq} = \frac{q}{\Delta V}$$

equivalent
capacitance

What single capacitor has the same properties as two capacitors in parallel? Ans: A capacitor with $C_{eq} = C_1 + C_2$

Capacitors



16.9 Dielectrics, Energy

Dielectric constant-effect on capacitance

Energy stored in a capacitor

Energy density (depends on E^2)

Biological Membranes

Dielectric material – insulators such as paper, glass plastic, ceramic. Used in the gap in capacitors.

“Dielectric Strength” - is the electric field at which conduction occurs through the material

dielectric material

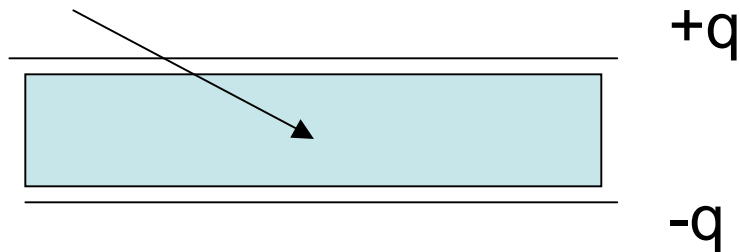

Polarization: “Stretching”

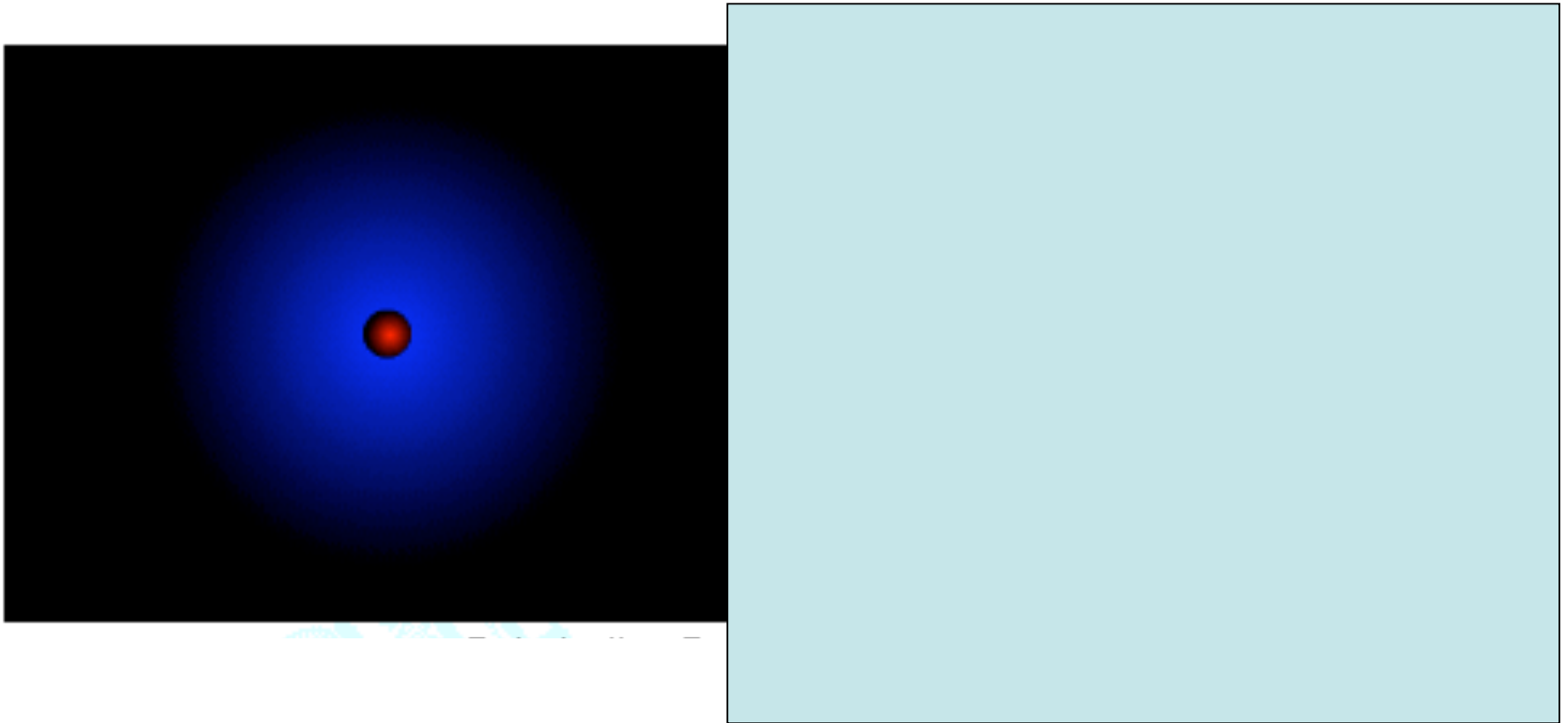

Electric Fields in Dielectric Filled Capacitors

$$E_{\text{effective}} = E - E_{\text{polarization}} = \frac{\sigma}{k\epsilon_0}$$

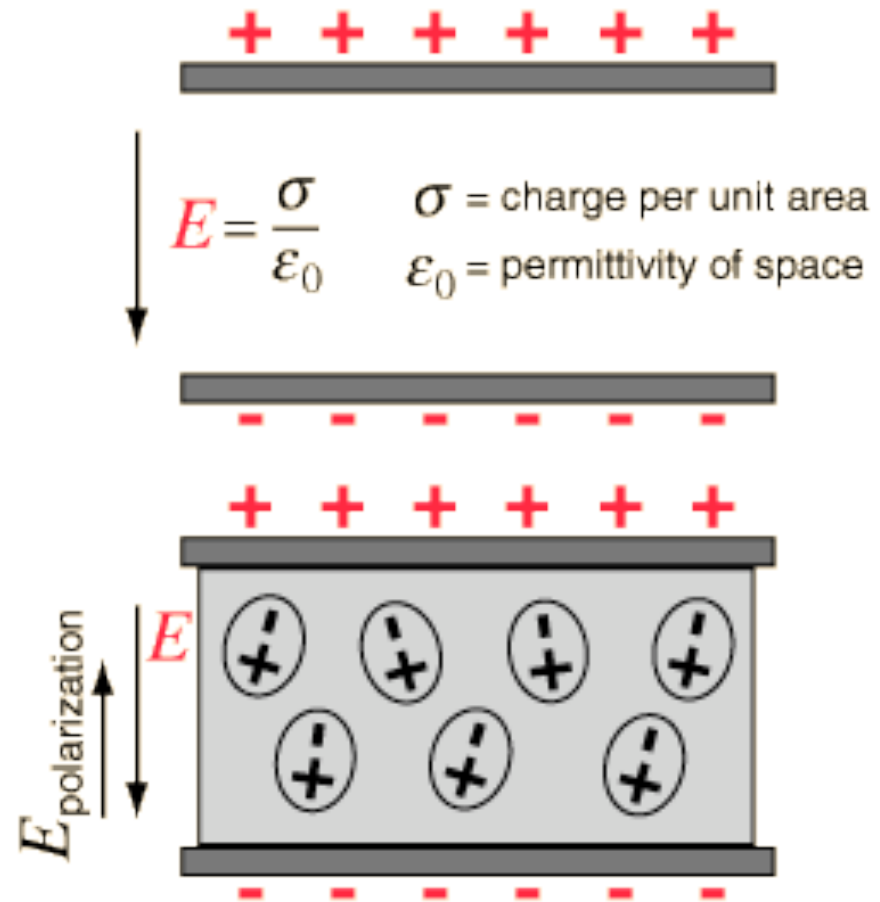

Effects of a dielectric material inserted into a capacitor, with charge q

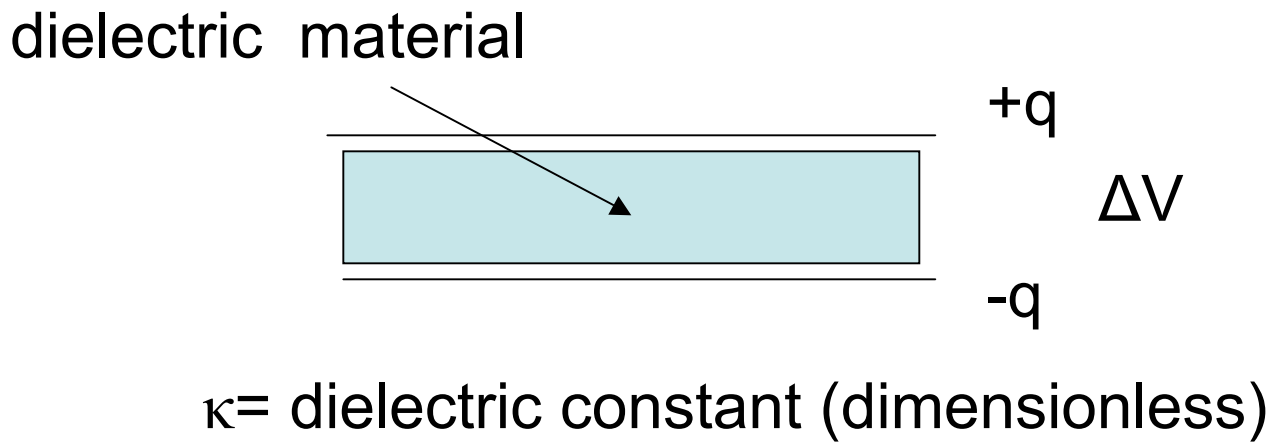
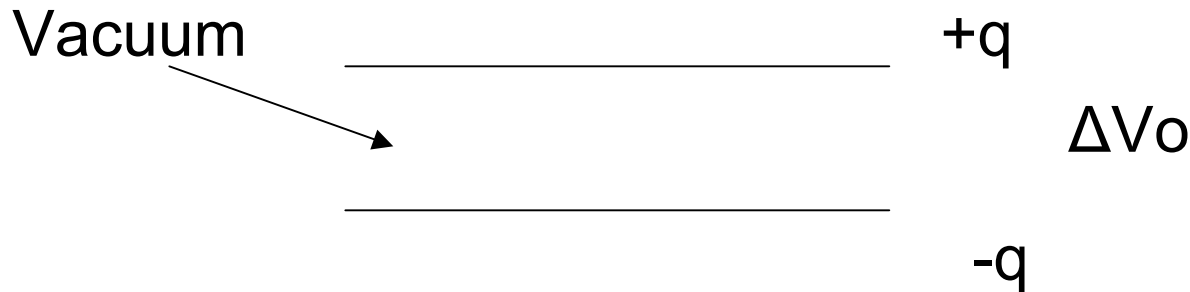

$$\Delta V = \frac{\Delta V_0}{\kappa}$$

Potential due to charge q decreases by κ

Dielectric Properties of Selected Materials

Material	dielectric constant, κ	Dielectric Strength (Volt/m)_____
Vacuum	1.000000	-----
Air	1.00059	2×10^6
Polystyrene	2.3	24×10^6
Paper	3.4	16×10^6
Pyrex	5.6	14×10^6
Water	80	-----

How does the capacitance change?

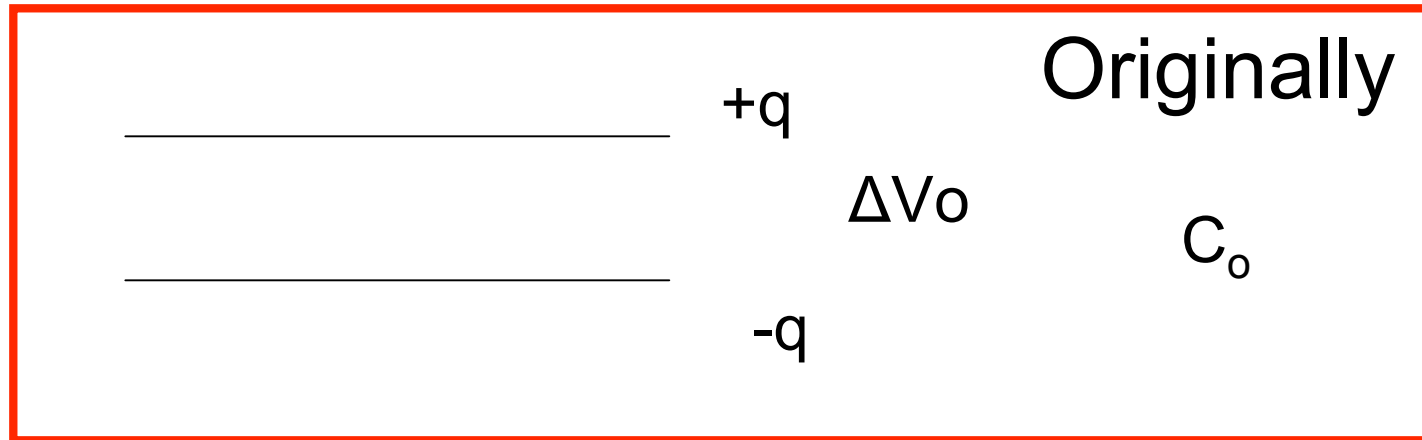

Add dielectric

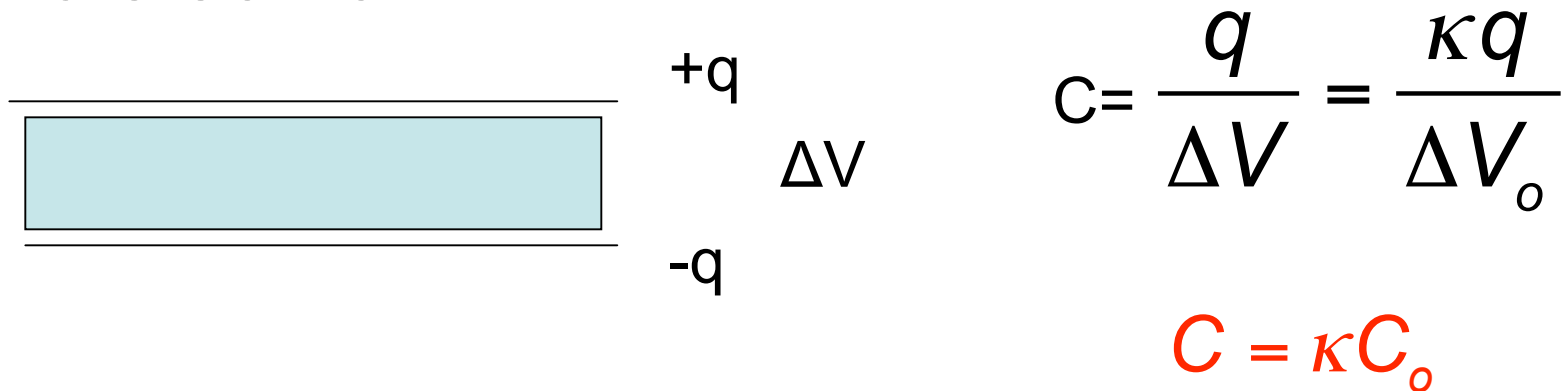

Capacitance increases

How does the E field change?

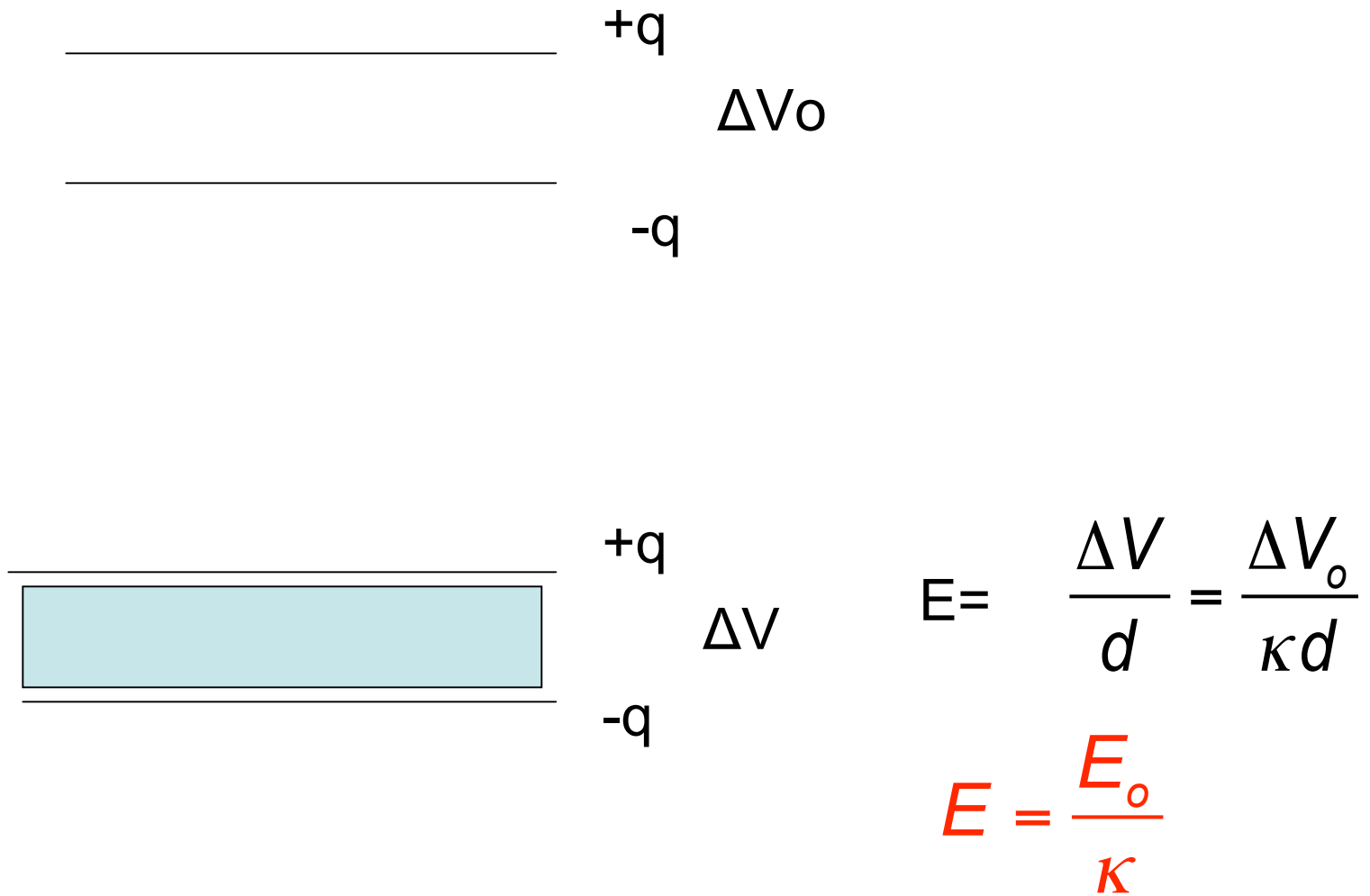

Electric field decreases (when not connected to a battery)

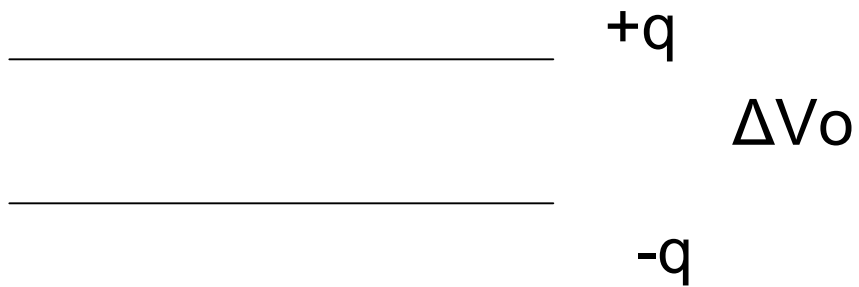

$$E = \frac{q}{\kappa \epsilon_0 A} = \frac{q}{\epsilon A}$$

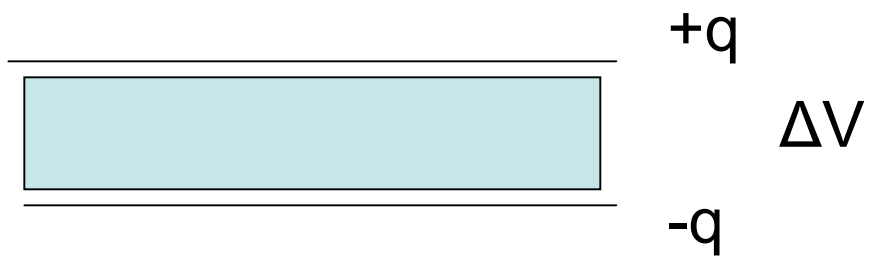

$$\epsilon = \kappa \epsilon_0$$

Permittivity is increased
Compared to vacuum

Example: A parallel plate capacitor consists of metal sheets ($A= 1.0\text{m}^2$) separated by a Teflon sheet ($\kappa=2.1$) with a thickness of 0.005 mm . (a) find the capacitance. (b) Find the maximum voltage. The maximum electric field across Teflon is $60 \times 10^6\text{ V/m}$. – this is its *dielectric strength*.

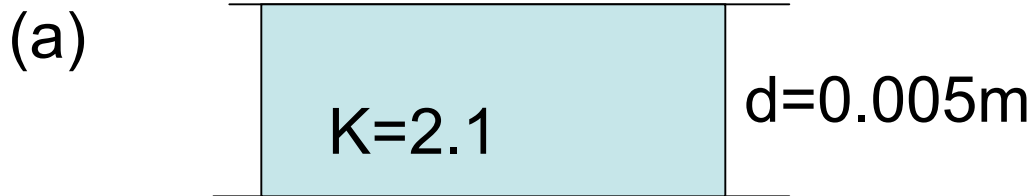

$$A=0.25\text{m}^2$$

$$C = \frac{\kappa \epsilon_0 A}{d} = \frac{2.1(8.8 \times 10^{-12})(1.0)}{0.005 \times 10^{-3}}$$

$$C = 3.7 \times 10^{-6} \text{ F}$$

A parallel plate capacitor consists of metal sheets ($A = 0.25\text{m}^2$) separated by a Teflon sheet ($\kappa = 2.1$) with a thickness of 0.005 mm. (a) find the capacitance. (b) Find the maximum voltage. The maximum electric field across Teflon is 60×10^6 V/m. (dielectric strength)

(b)

$$\Delta V_{\max} = E_{ds} d = 60 \times 10^6 (0.005 \times 10^{-3}) = 300\text{V}$$

Molecular basis for dielectric constant

Dipolar molecules.

e.g. water

are oriented in
an E field

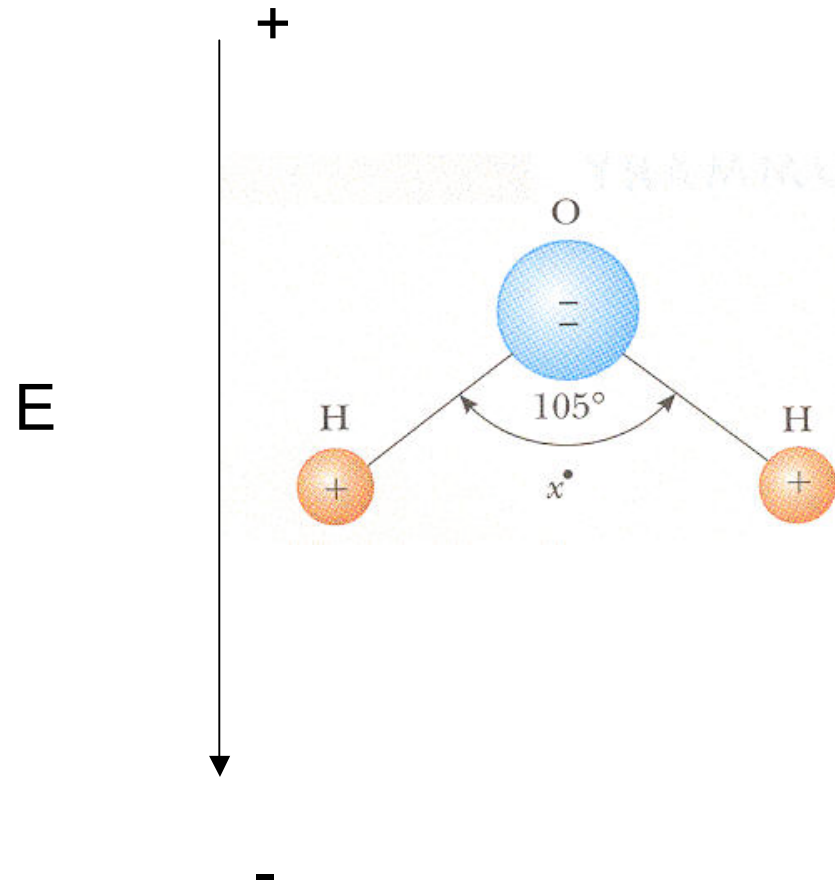

Oriented molecules decrease the net charge near the plates

The E field in the Capacitor is reduced

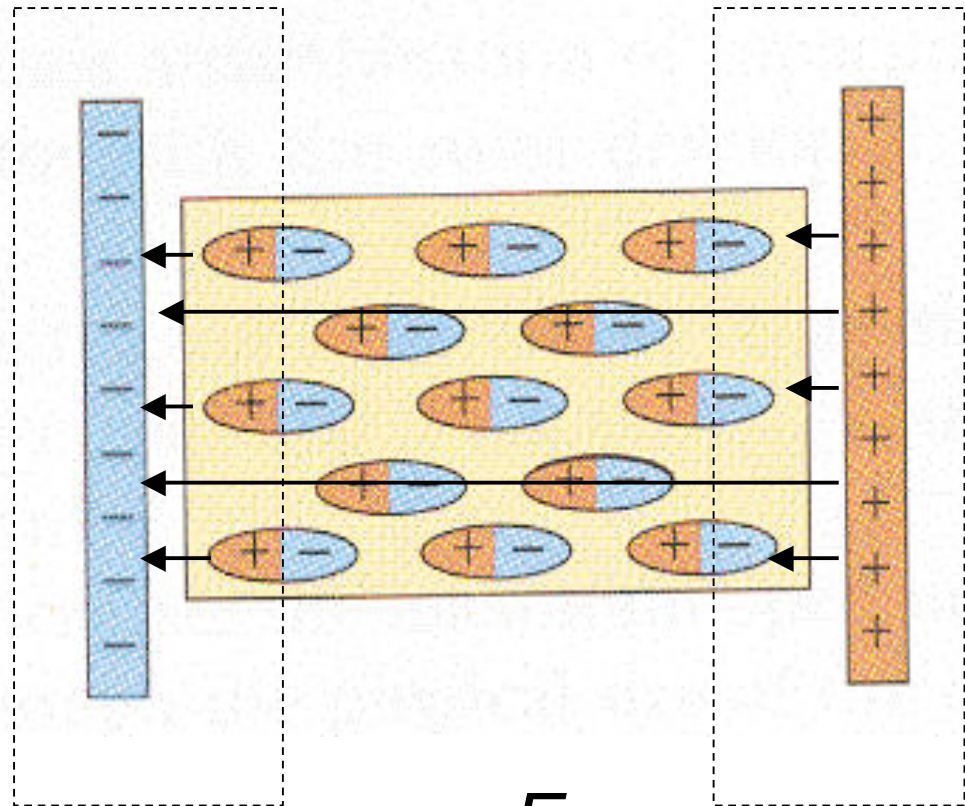

$$E = \frac{E_0}{\kappa}$$

Polarization of Dielectric

Unpolarized



Polarized by an applied electric field.

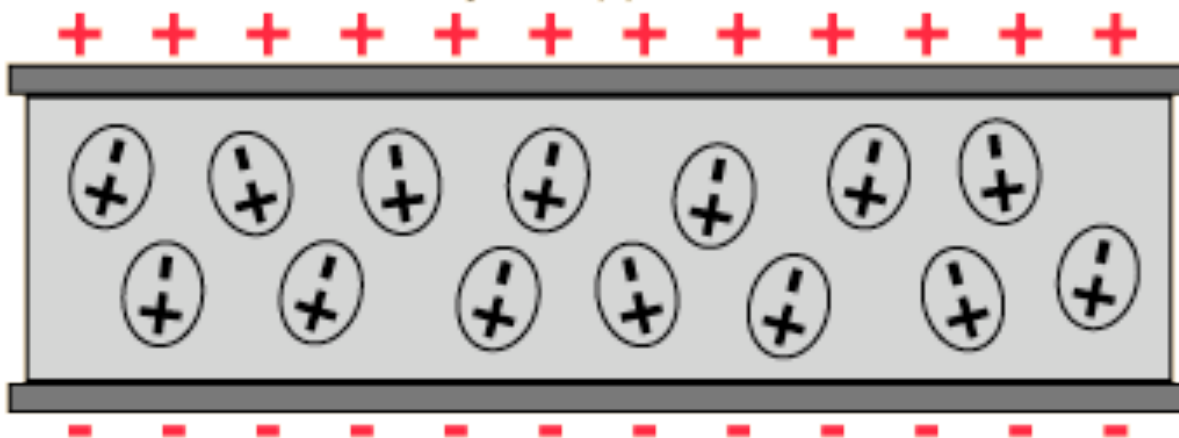

Dielectric Screening

High dielectric constant of water allows ions to dissociate

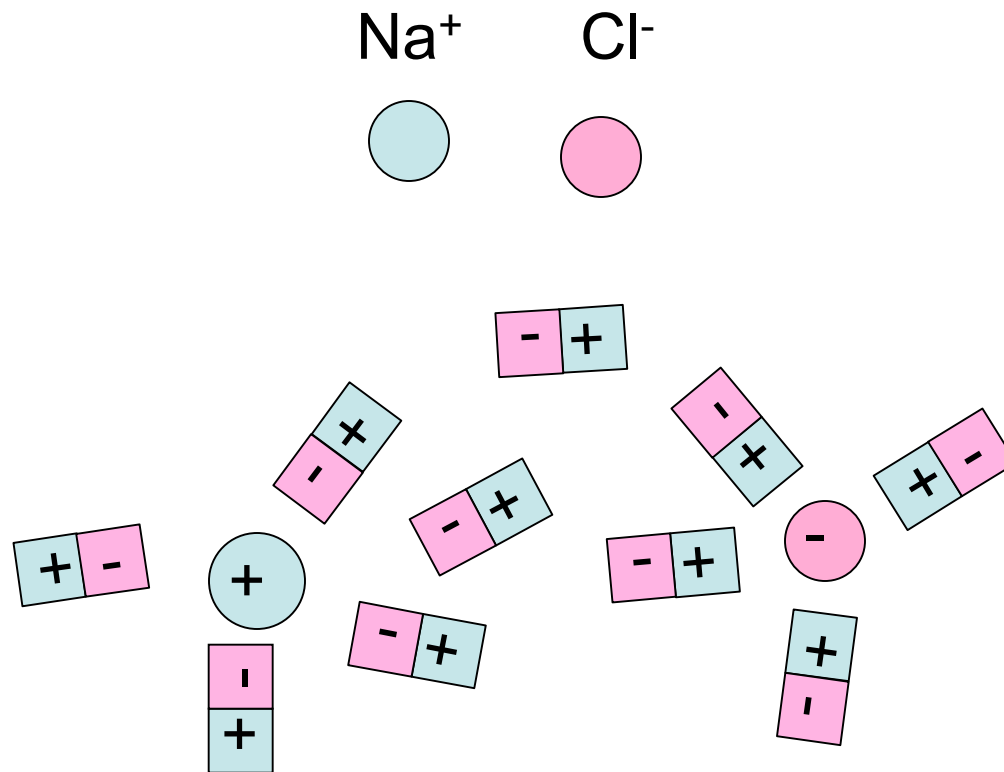

$$V = \frac{V_o}{\kappa} = \frac{V_o}{80}$$

Find the potential energy in electron volts for the interaction of Na⁺ and Cl⁻ separated by 0.5 nm in water.

$$PE = \frac{q_{Na}q_{Cl}}{4\pi\kappa\epsilon_0 r} = \frac{-(1.6 \times 10^{-19})^2}{4\pi(80)(8.8 \times 10^{-12})(0.5 \times 10^{-9})}$$

$$PE = -5.8 \times 10^{-21} \text{ J} \times \left(\frac{1 \text{ eV}}{1.6 \times 10^{-19} \text{ J}} \right)$$

PE = -0.036 electron Volts

comparable to thermal energies (kinetic energy of the ion) about 0.025 eV at room temperature

Energy stored in a capacitor.

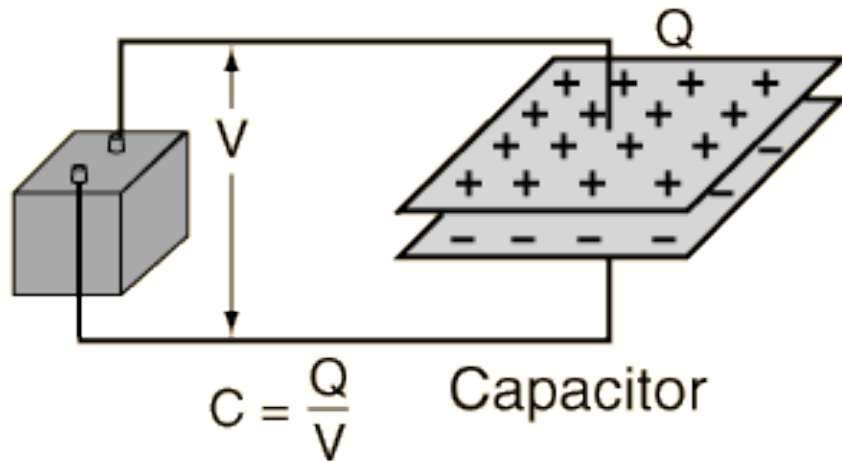

$$Ed = \frac{Fd}{q} = \frac{W}{q} = \Delta V \quad \text{For constant electric field.}$$

$$\begin{aligned} E &= \frac{F}{q} && \text{General} \\ &&& \text{definition} \\ W &= q\Delta V && \text{relationships} \end{aligned}$$

$$\begin{aligned} E &= \frac{V}{d} && \text{Constant field} \\ &&& \text{special case} \\ V &= Ed && \text{relationships} \end{aligned}$$

Work done to charge a capacitor

$$V_f - V_i = \frac{Fd}{q} = -Ed$$

Moving a charge from bottom to top plate requires work and raises voltage.

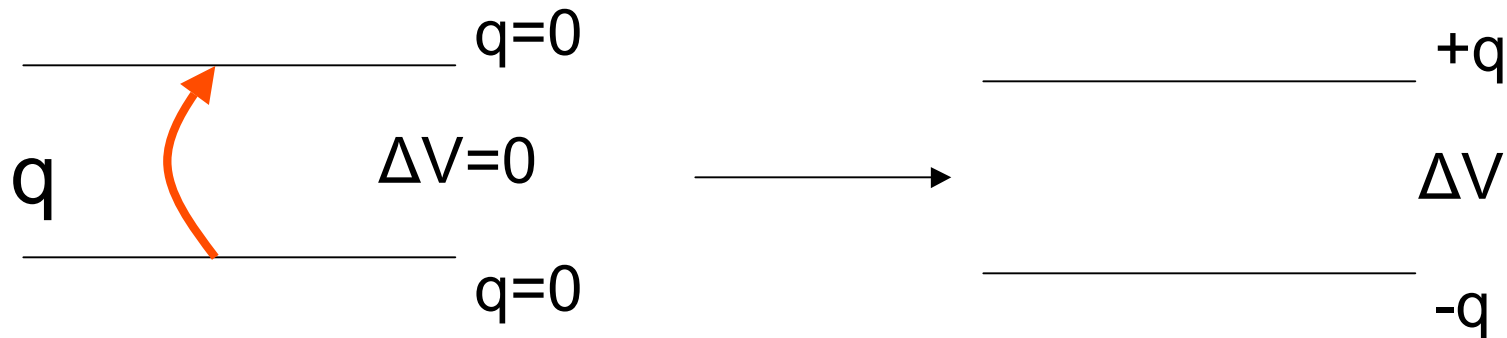
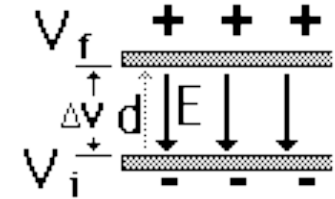

$$W = \frac{1}{2} \frac{q^2}{C} = \frac{1}{2} C \Delta V^2$$

So *work* depends on the *square* of q or ΔV

A parallel plate capacitor consists of metal sheets ($A= 1\text{m}^2$) separated by a teflon sheet ($\kappa=2.1$) with a thickness of 0.005 mm. Find the maximum energy that can be stored.

$$C=3.7 \times 10^{-6}\text{F} \quad \Delta V_{\text{max}}=300\text{V}$$

C

$$\text{Energy} = \frac{1}{2}C\Delta V^2 = \frac{1}{2}(3.7 \times 10^{-6})(300)^2$$

$$\text{Energy} = 1.7 \times 10^{-1}\text{J}$$

(quick quiz 16.6)

Insert the dielectric material with dielectric constant κ into the capacitor keeping the voltage source connected.

Find C, q, E, PE

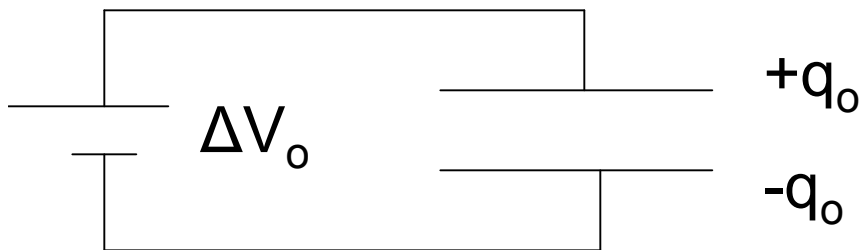

C_0

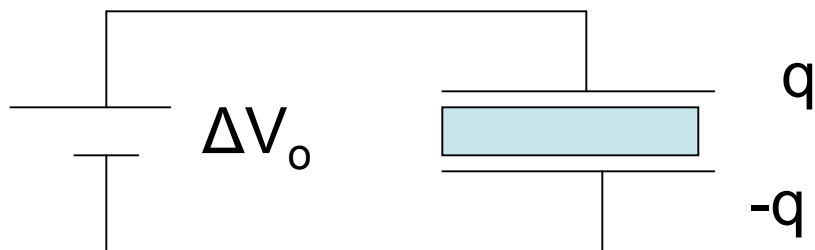

$$C = \kappa C_0$$

$$q = CV = \kappa C_0 V_0 = \kappa q_0$$

$$E = \frac{\Delta V}{d} = \frac{\Delta V_0}{d} = E_0$$

$$PE = \frac{1}{2} C \Delta V^2 = \frac{1}{2} \kappa C_0 \Delta V_0^2 = \kappa PE_0$$

Energy Density in a Capacitor

Suppose you wanted to store a large amount of energy in a capacitor with a given volume of 1m^3 using Teflon as the dielectric (dielectric strength of $60 \times 10^6 \text{ V/m}$). What is the maximum energy that could be stored?

$$\text{Energy} = \frac{1}{2} CV^2$$

$$C = \frac{A\kappa\epsilon_0}{d}$$

$$\text{Energy} = \frac{1}{2} \frac{A\kappa\epsilon_0}{d} V^2 = \frac{1}{2} \frac{Ad\kappa\epsilon_0}{d^2} V^2 = \frac{1}{2} \kappa\epsilon_0 E^2 (\text{volume})$$

$$\frac{\text{Energy}}{\text{volume}} = \frac{1}{2} \kappa\epsilon_0 E^2$$

The energy density depends only on the E field squared.

For the maximum electric field = dielectric strength

$$\text{Energy} = \frac{1}{2} \kappa \epsilon_0 E^2 (\text{volume})$$

$$\text{Energy} = \frac{1}{2} (2.1)(8.8 \times 10^{-12})(60 \times 10^6)^2 (1)$$

$$\text{Energy} = 3.4 \times 10^4 \text{ J}$$

For a 1 m³ capacitor at
the maximum voltage.

For comparison the energy content of burning

1 gallon of gasoline is $1.3 \times 10^8 \text{ J}$

Chemical energy has a higher energy density.

Capacitance of Biological Membranes

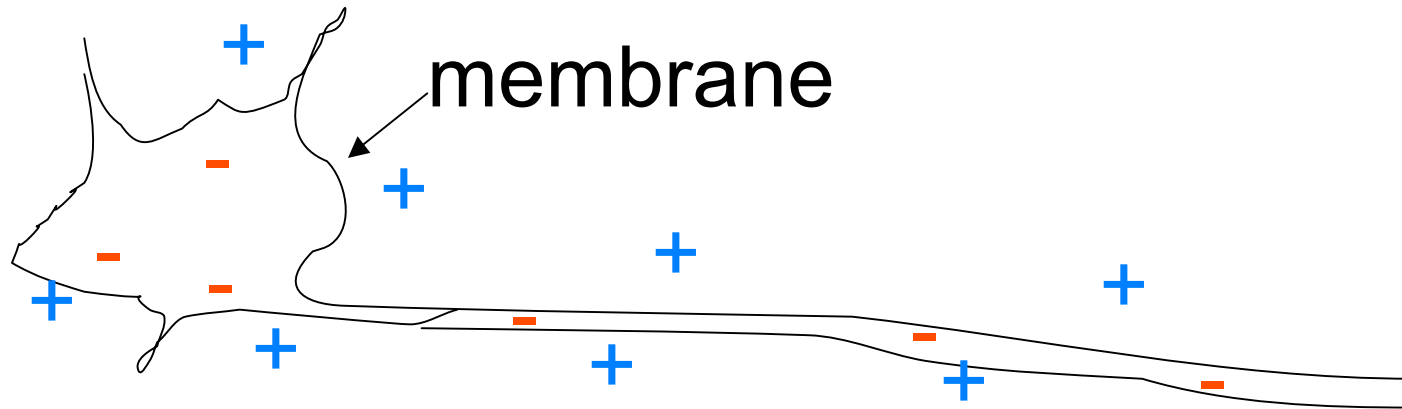

Axon - Nerve cells

Potential difference across the membrane

Nerve transmission – involves a discharge of membrane potential

Biological membranes –Capacitance

The low dielectric portion of a biological membrane has a thickness of 2.0 nm. Assume that it has a dielectric constant of 2.5 (silicone oil) find the capacitance of 1m² of membrane.

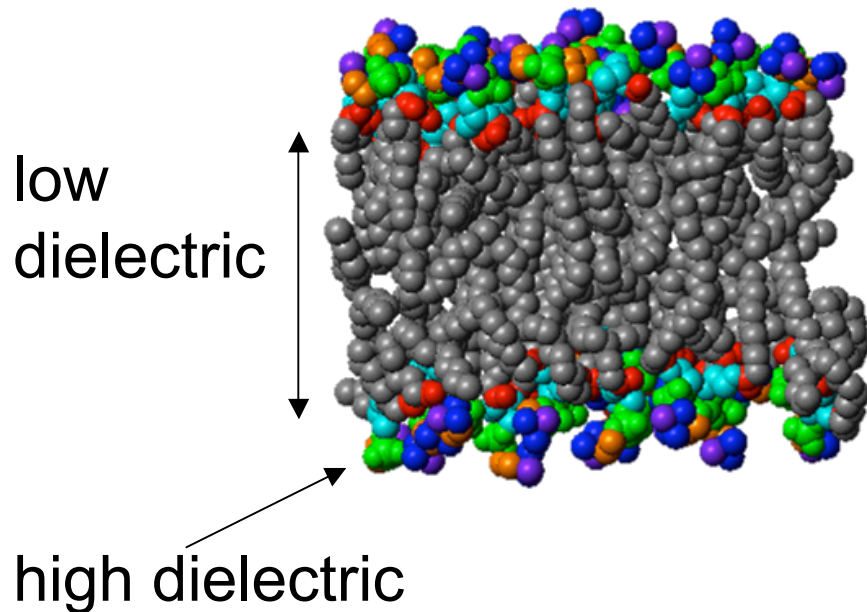

$$C = \frac{\epsilon A}{d} = \frac{\kappa \epsilon_0 A}{d}$$

$$C = \frac{2.5(8.8 \times 10^{-12})(1)}{2.0 \times 10^{-9}}$$

$$C = 1.1 \times 10^{-2} F$$

High Capacitance

Compare to $3.7 \times 10^{-6} F$ for 1m² the Teflon capacitor.

A nerve cell has a potential across it of 60 mV. Find the density of charges on the membrane that can give rise to this potential

$$\Delta V = 60 \text{ mV}$$

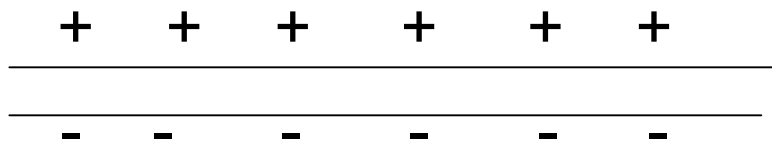

$$E = \frac{\Delta V}{d} = \frac{60 \times 10^{-3}}{2 \times 10^{-9}} = 3 \times 10^7 \text{ V/m}$$

$$E = \frac{q}{A\kappa\epsilon_0} = \frac{\sigma}{\kappa\epsilon_0}$$

This is close to the dielectric strength

$$\sigma = \kappa\epsilon_0 E = 2.5(8.8 \times 10^{-12})(3 \times 10^7)$$

$$\sigma = 6.6 \times 10^{-4} \text{ C/m}^2$$

This corresponds to an ion density of 4.1×10^{-3} ions /nm² or a distance between ions of about 16 nm. A small number of excess charges.

HOMEWORK...GET OUT YOUR
CLICKER

1) 16.5 The potential difference between the accelerating plates of a TV set is about 25 kV. If the distance between the plates is 1.5 cm, find the magnitude of the uniform electric field in the region between the plates.

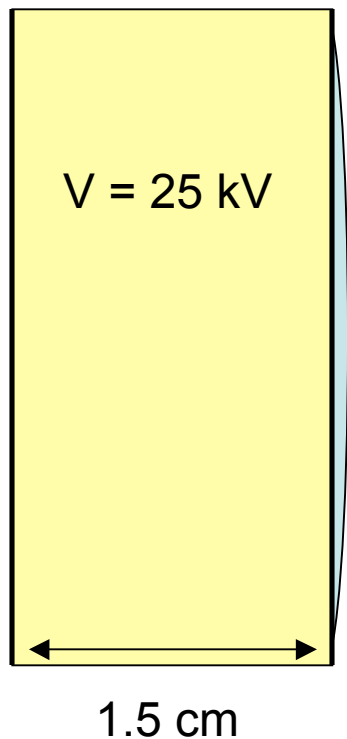

- A) 17 N/C
- B) $1.7 \times 10^{-5} \text{ N/C}$
- C) $1.7 \times 10^6 \text{ N/C}$



2) 16.23 Consider the Earth and a cloud layer 800 m above the planet to be the plates of a parallel-plate capacitor. If the cloud layer has an area of $1.0 \times 10^6 \text{ m}^2$, what is the capacitance?

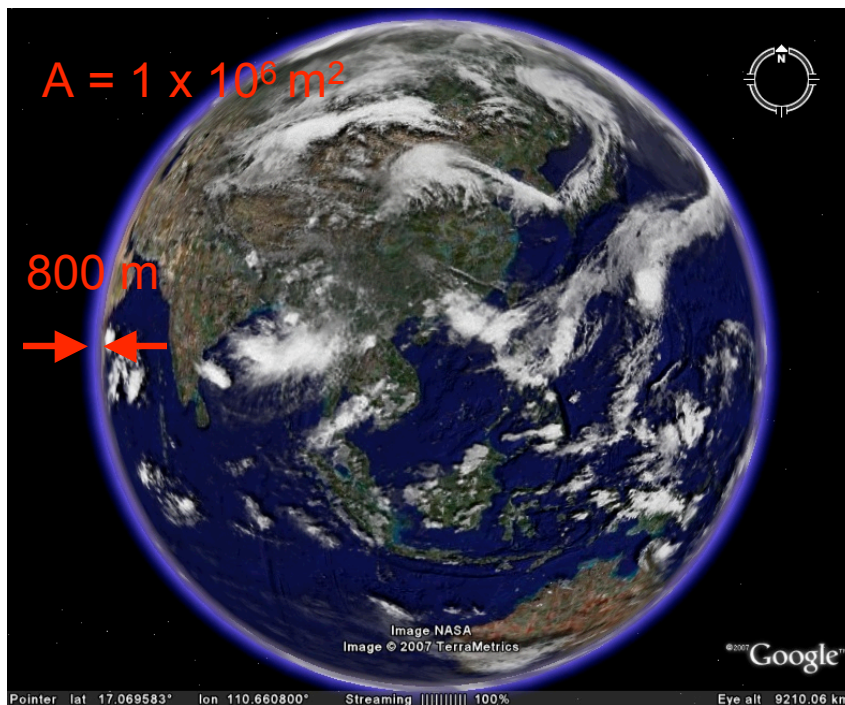

- A) 11 nF
- B) 85 μF
- C) 85 nF
- D) $1 \times 10^7 \text{ F}$



3) 16.31 Find the equivalent capacitance of the capacitors in the figure.

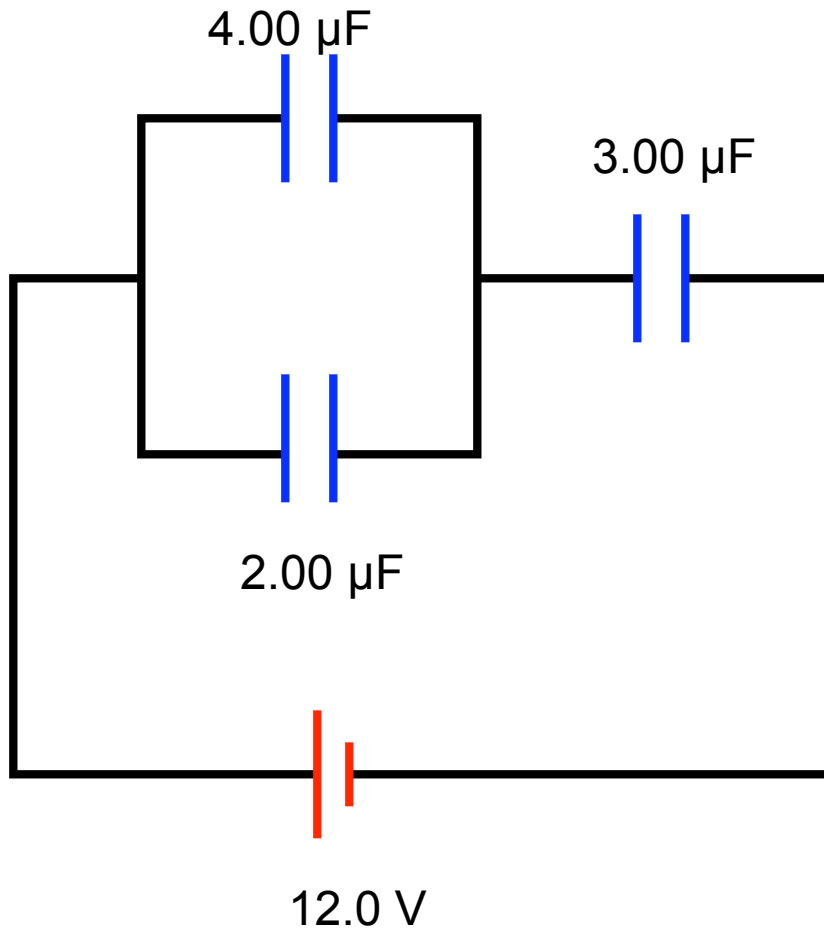

- A) 4.3 μF
- B) 9.0 μF
- C) 2.0 μF
- D) .92 μF



1) 16.5 The potential difference between the accelerating plates of a TV set is about 25 kV. If the distance between the plates is 1.5 cm, find the magnitude of the uniform electric field in the region between the plates.

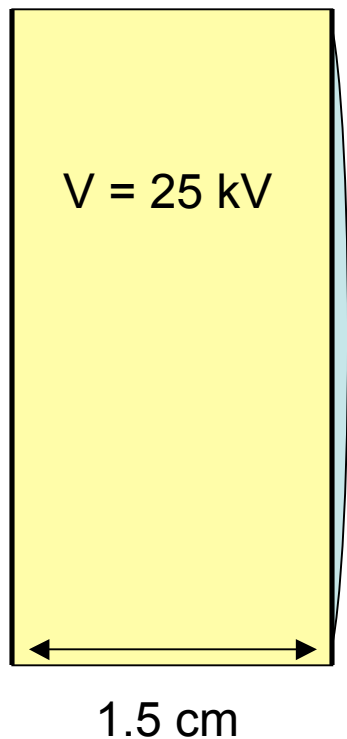

- A) 17 N/C
- B) $1.7 \times 10^{-5} \text{ N/C}$
- C) $1.7 \times 10^6 \text{ N/C}$



2) 16.23 Consider the Earth and a cloud layer 800 m above the planet to be the plates of a parallel-plate capacitor. If the cloud layer has an area of $1.0 \times 10^6 \text{ m}^2$, what is the capacitance?

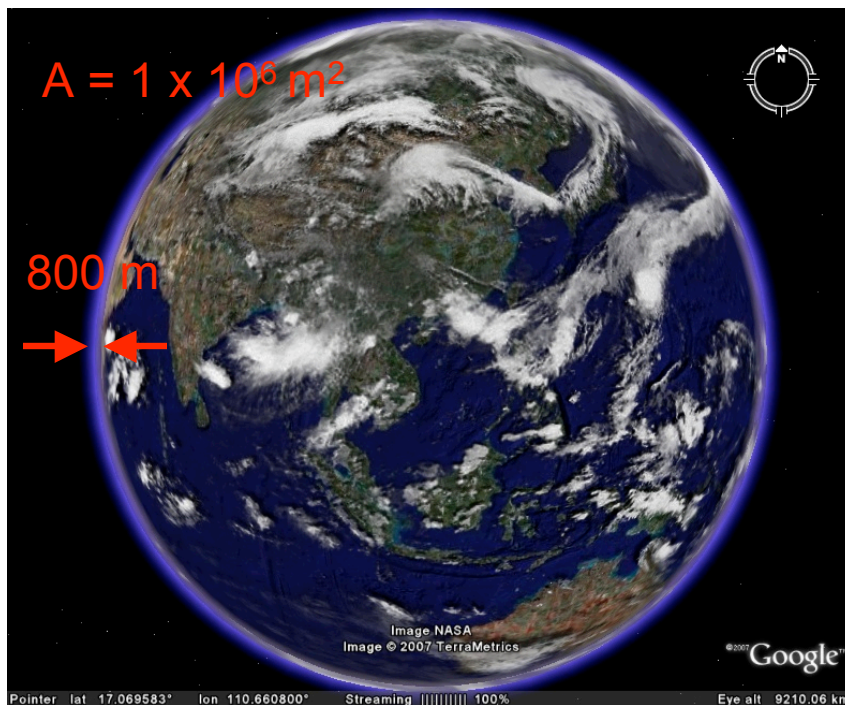

- A) 11 nF
- B) 85 μF
- C) 85 nF
- D) $1 \times 10^7 \text{ F}$



3) 16.31 Find the equivalent capacitance of the capacitors in the figure.

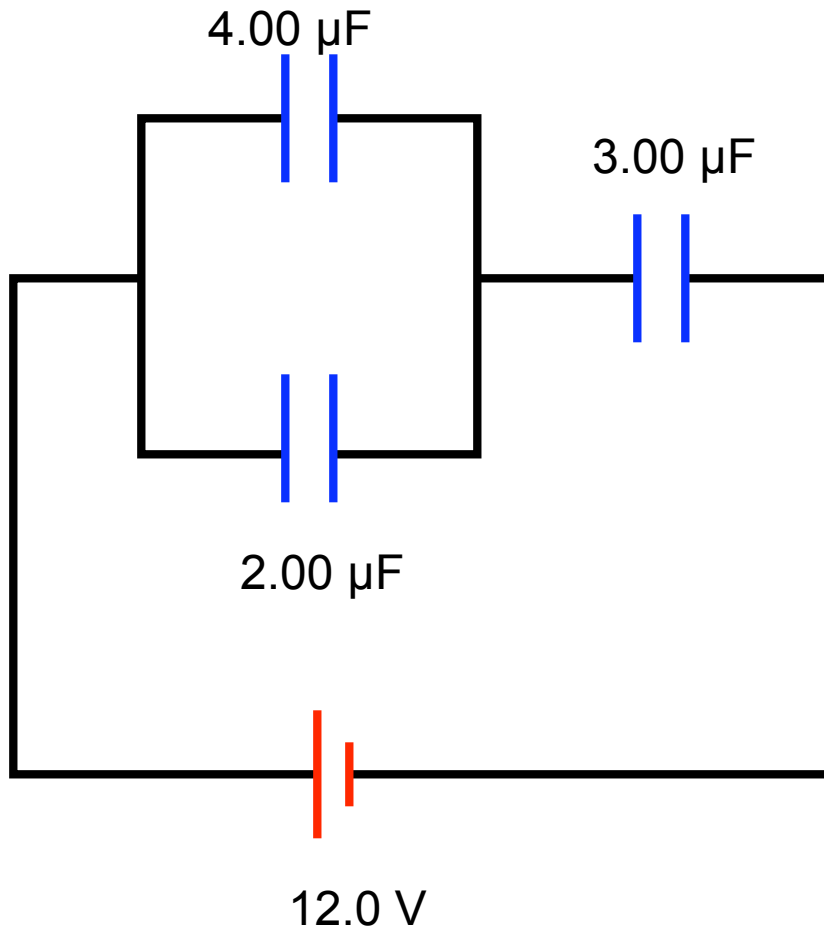

- A) 4.3 μF
- B) 9.0 μF
- C) 2.0 μF
- D) .92 μF

