

Introduction

In this lab we will examine more complicated circuits. First, you will derive an expression for equivalent resistance using Kirchhoff's Rules. Then you will discuss the physics underlying Kirchhoff's rules. Then you will practice drawing circuit diagrams from real circuits and vice versa. Finally, you will use Kirchhoff's rules and your knowledge of equivalent resistance to analyze complex circuits.

Pre-lab questions:

How to read Resistor Color Codes

#	Color	Mnemonic
0	Black	Big
1	Brown	Boys
2	Red	Race
3	Orange	Only
4	Yellow	Young
5	Green	Girls
6	Blue	But
7	Violet	Violet
8	Gray	Generally
9	White	Wins

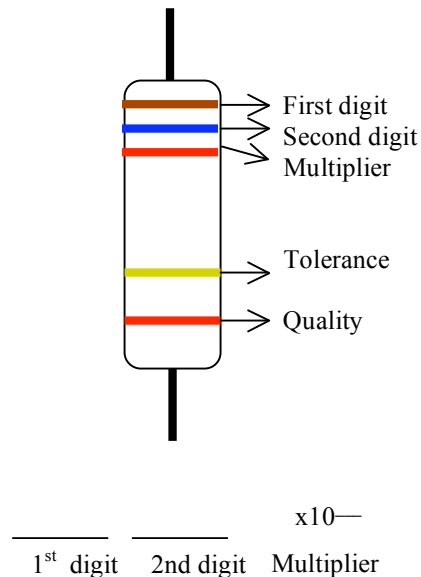

First, find the tolerance band. It will typically be gold (5%) or silver (10%).

Starting from the other end, identify the first band - write down the number associated with that color; in this case Brown is 1.

Now 'read' the next color. Here it is blue, so write down a '6' next to the 1. (you should have '16' so far.)

Now read the third, or 'multiplier', band and write down that number of zeros. (It is called a multiplier band because you are multiplying the first two bands by 10 to the power of the number of the third band.)

In this example the multiplier band is Red (2) so the multiplier is 10^2 . The resistor value is 16×10^2 ohms or 1600Ω or $1.6k\Omega$.

If the multiplier band is Gold move the decimal point one place to the left. If the multiplier band is Silver, move the decimal point two places to the left.

The tolerance band tells you how close to the stated value you can expect the actual resistance to be. Gold indicated 5% tolerance and Silver indicated 10% tolerance. Therefore, Gold tolerance resistors are between 95% and 105% of the value indicated by the color bands.

If the resistor has one more band past the tolerance band, it is a Quality band. The Quality band indicates the failure rate of the resistor when operated at full power.

1. Resistor color codes:
 - a. What is the resistance of a resistor with the band colors Black Gray Brown?
 - b. What colors would you see on a $20\text{ k}\Omega$ resistor?

2. One light bulb is marked “20 W 120 V” and another “60 W 120 V”. This means that each transforms this amount of electrical energy into light and heat per second when plugged into a constant 120-V potential difference.
 - a. Find the resistance of each bulb. When they are connected to a 120 V power supply which bulb is brighter?
 - b. How long does it take for 10.00 C to pass through the dim bulb? How is this charge different upon its exit versus its entry into the bulb?
 - c. How long does it take the dim bulb to dissipate 5.00 J of energy?
 - d. Find the cost of running the dim bulb continuously for 10.0 days if the electric company sells its product at \$0.08 per kilowatt-hour [kWh].
 - e. What physics quantity does the electric company sell? What is the price for one SI unit of this quantity?
 - f. Assume you can buy gasoline at \$3.50 per gallon and that each gallon contains 114000 Btu. What is the ratio of the cost of energy from the electrical power company over the cost of energy from the gas pump?

3. Use Kirchoff's rules to find the current in each of the three resistors in the circuit shown at right.

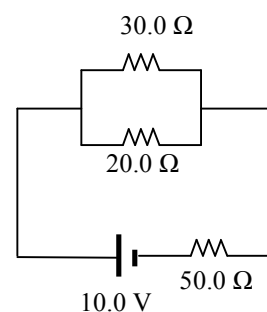

Group Activity:

Consider this circuit, with two resistors and two batteries. You can assume V_2 is 6V.

- What is the current through R_2 ?
- What is the resistance value of R_2 ?
- What is the current through battery V_1 ?
- What is the current through battery V_2 ?
- If R_1 is 5 ohms, what is V_1 ?

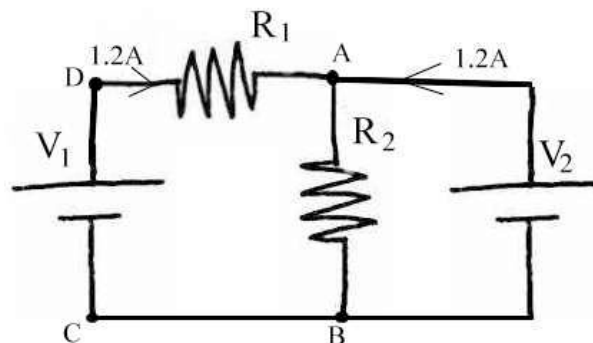

A. Equivalent Resistance

Consider the circuit shown to the right:

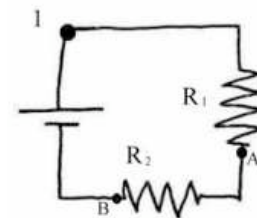

- What do you know about the current passing through point 1, and through each of the two resistors at points A and B?
 - Write an equation reflecting the relationship between the current at these three points.
 - Is your equation consistent with Kirchhoff's Junction Rule? Explain.
- What do you know about the relationship between the voltage drop across the two terminals of the battery, and the voltage drop across each of the resistors?
 - Write an equation reflecting the relationship between the voltage drop across the battery and the voltage drop across each resistor.
 - Is your equation consistent with Kirchhoff's Loop Rule? Explain.
- When you can replace multiple resistors in a circuit with a single resistor without changing the current, the value of the resistor is called the **equivalent resistance**.

- Find an expression for the equivalent resistance in terms of the voltage of the battery and the current at point 1 using Ohm's Law.
- Solve your three equations (found using Kirchhoff's Junction Rule, Kirchhoff's Loop Rule, and Ohm's Law) to find the equivalent resistance in terms of resistances of the other two resistors only.

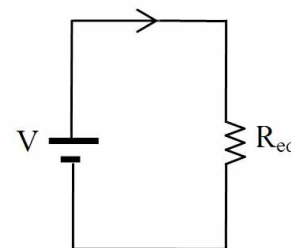

B. Deeper Meaning of Kirchhoff's Rules

- B1. What is Kirchhoff's Junction Rule? For the group activity calculate how much charge is delivered to point A every second. How much charge is removed from point A? Do you expect charge to be building up anywhere in this circuit? Is the flow of charge into and away from point A consistent with conservation of charge?
- B2. For the group activity assume point B is at 0 V. Calculate the voltages at each point around the loop ABCD and back to A. Calculate the electrical potential energy a positive charge of 1.6×10^{-19} C gains or loses moving from one point to the next around the loop. When this charge returns to point A does it have the same energy as it had when it left A? (In this case we consider a positive charge although we know currents in metals are carried by electrons. It is easier to understand the gain and loss of energy for a "fake" positive charge).
- Where did our charge get its energy from?
 - Where and how did the charge lose the energy it gained?
 - Explain how conservation of energy is related to Kirchhoff's Loop Rule.

C. Creating a Diagram from a Circuit.

- C1. At the front of the classroom, you will find several circuits set up. Pick two circuits and draw a circuit diagram for each, without consulting the other members of your lab group. Once you've finished, compare your diagrams.
- Are they the same?
 - What have you done differently?

- C2. When you have come to an agreement with your lab partners, verify with the TA that your diagrams are accurate.

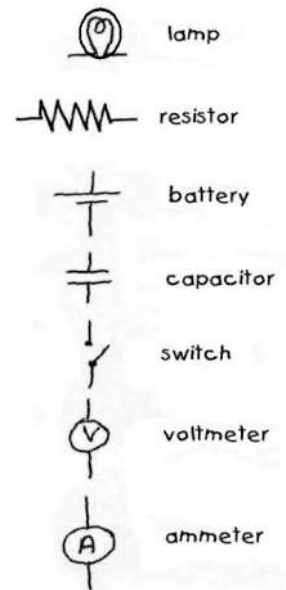

D. Creating Circuits from Diagrams

- D1. Build the following circuit. Assume all resistors have a resistance of $10\ \Omega$ and PS is a power supply set at 4 volts.

- Do both light bulbs glow? Do you expect them to? Explain. If they both glow, are they the same brightness? If not, why do you think this is?
- Do you expect the bulbs to have the same current flowing through them? Why or why not?
- Using LoggerPro, measure the current flowing in the circuit at Point A. Compare this to the readout on the power supply. Are they the same?
- The resistance of each light bulb is $1\ \Omega$ when it is off, $4\ \Omega$ when it glows red and $6\ \Omega$ when it shines brightly. . Calculate the equivalent resistance of the whole circuit when the power supply is set at 4V. Include everything from point A through all the resistors and light bulbs. From the equivalent resistance calculate the current at point A and compare with your measurement of this quantity.
- Build a circuit with the power supply still at 4V, but only one resistor with a resistance equal to the equivalent resistance of the circuit D1.
 - What do you expect the current to be in this circuit?
 - What do you measure the current to be in this circuit?
 - Is this the same as the current you found for point A of Circuit D1?

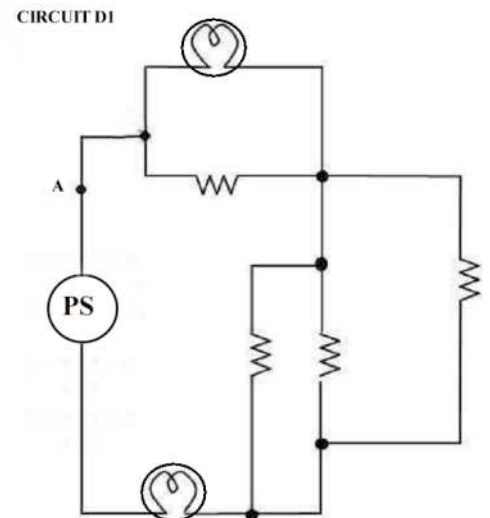

D2. Build circuit D2. Assume all resistors have a resistance of $10\ \Omega$ and the power supply is set to $7V$. **CAUTION: Build the circuit with the power supply turned OFF. Set the supply to $7V$ with the circuit disconnected from the supply. When you have everything connected turn the supply on for short periods only (5 seconds or less).**

- When the power is ON do both light bulbs glow? Do you expect them to? Explain. If they both glow, are they the same brightness? If not, why do you think this is?
- Do you expect the bulbs to have the same value for their currents? Why (or why not)?
- What is the equivalent resistance of this circuit? (Use the values in the previous experiment to select the appropriate value of the resistance of the light bulb).
- List all the evidence you have that current is flowing in the circuit when the power supply is turned on. (You should have at least three different indicators).
- What current is delivered from the power supply? Use this to determine experimentally the equivalent resistance of the circuit. Does it agree with your calculations?

Circuit D2

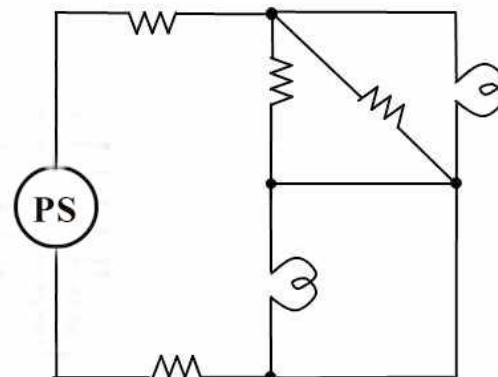

E. Analyzing Complex Circuits

E1. Build the circuit shown, using a $1.5V$ battery and $10\ \Omega$ resistors.

E2. Assuming the negative terminal of the battery to be at zero electric potential, what do you expect the electric potential to be at point A, point B, and point C?

- Use LoggerPro to measure the potential at those points. Do your measurements agree with what you expect?

E3. What do you expect the current going through R_1 , R_2 , and R_3 to be? Is the current the same or different through each resistor?

- Use LoggerPro to measure the current through each of the resistors. Do your measurements agree with what you expect?

E4. How much potential energy does an electron lose when it travels from point C to point B?

- Does it matter which resistor (R_2 or R_3) the electron goes through? Why or why not?

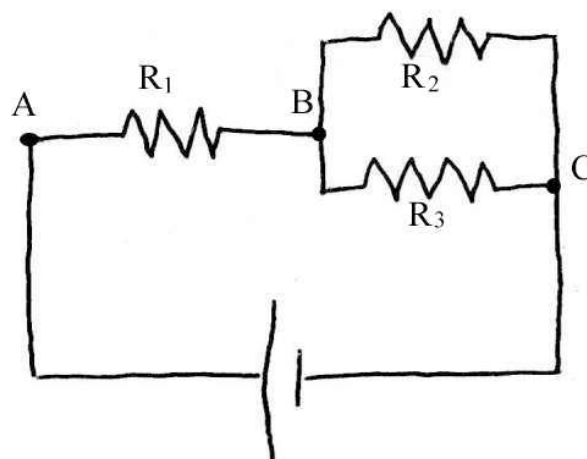

- E5. Build the following circuit. You **must** use the 1.5V rechargeable D cells for this exercise. Ask your TA for these batteries and return them when you are finished. Use $22\ \Omega$ for R_1 and $10\ \Omega$ for R_2 and R_3 .

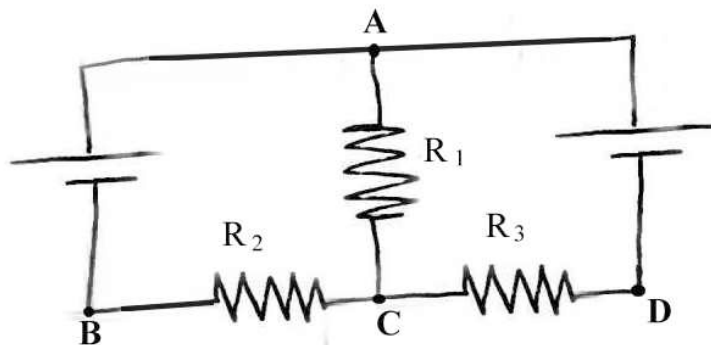

- E6. Assuming the positive terminals of both batteries are at 1.5V electric potential, what do you expect the electric potential to be at points A, B, C and D?
- Use LoggerPro to measure the potential at those points. Do your measurements agree with what you expect?
- E7. What do you expect the current going through R_1 , R_2 and R_3 to be? Which direction is the current flowing?
- Use LoggerPro to measure the current through each resistor. Do your measurements agree with what you expect?
- E8. Consider electrons that come from the battery on the left and pass through the wire at point B. These electrons flow through R_2 then R_1 and reach point A. At point A how many of these electrons return to the battery at the left?

Post-lab Questions:

- Is it possible to connect two identical batteries to make two bulbs in series light just as brightly as one alone across one battery? If so, sketch and explain the circuit diagram. If not, explain your reasoning.
- Bulbs A, B and C in the circuit to the right are identical.
 - Rank in order, from most to least, the brightness of the three bulbs. Explain your reasoning.
 - Suppose a wire is connected between points 1 and 2. What happens to each bulb? Does it get brighter, dimmer, or go out? Explain your reasoning.
 - What happens to the current drawn from the battery when the wire is connected?
- Your TA will inform you which section of this lab you should write up.

