

Electric Potential Difference, ΔV

$$\Delta V = V_B - V_A = \Delta U / q$$

Units: Joule/Coulomb = VOLT

Scalar quantity

Relation between ΔV and E :

For a uniform E -field: $\Delta V = -Ed$

E has units of $V/m = N/C$

($V / m = J / Cm = Nm / Cm = N / C$)

$$V_B - V_A = \Delta V = - \int_A^B \vec{E} \cdot d\vec{s} = -E \int_A^B ds = -Ed$$

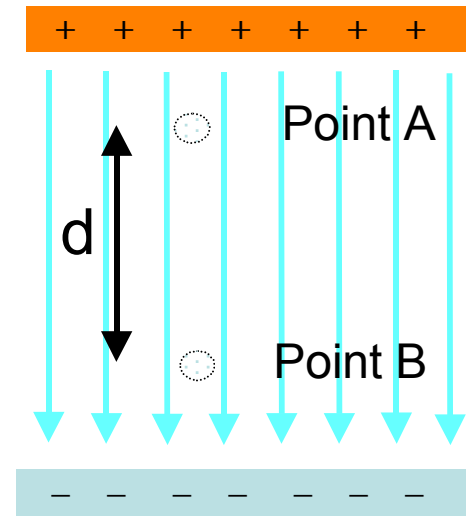

V (absolute)

V usually taken to be 0 at some point, such as $r=\infty$

V at any point = (work required by us to bring in a test particle from infinity to that point) / (charge of test particle)

$$V = -\int_{\infty}^P \vec{E} \cdot d\vec{s}$$
$$U = \left(-\int_{\infty}^P \vec{E} \cdot d\vec{s} \right) q_0$$

Assuming the source charge is positive, we're moving against the E-field vectors (towards higher potential) as we move towards point P. $d\vec{s}$ and \vec{E} are opposing, and their dot product is negative. So U ends up being a positive value.

More general case: When moving a charge along a path not parallel to field lines

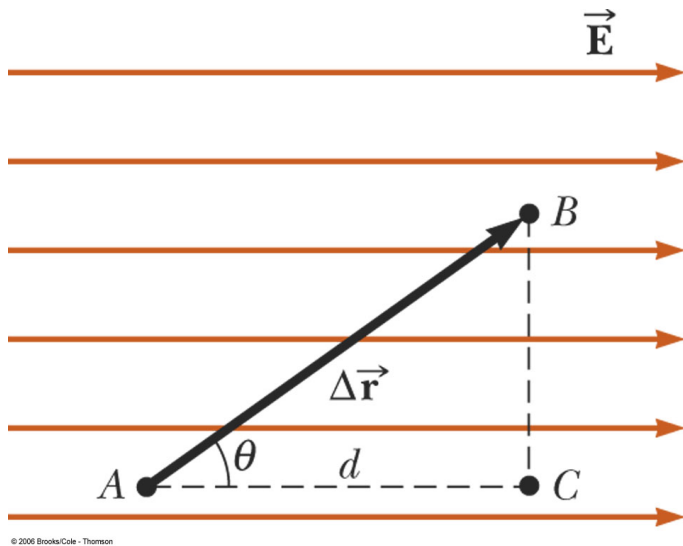

Now consider the more general case of a charged particle moving between two points in a uniform electric field as in Figure 20.2. If $\Delta \vec{r}$ represents the displacement vector between points A and B, Equation 20.3 gives

$$\Delta V = - \int_A^B \vec{E} \cdot d\vec{s} = - \vec{E} \cdot \int_A^B d\vec{s} = - \vec{E} \cdot \Delta \vec{r} \quad [20.4]$$

where again we are able to remove \vec{E} from the integral because the electric field is uniform. Furthermore, the change in electric potential energy of the charge-field system is

$$\Delta U = q_0 \Delta V = -q_0 \vec{E} \cdot \Delta \vec{r} \quad [20.5]$$

Finally, our results show that all points in a plane *perpendicular* to a uniform electric field are at the same potential as can be seen in Figure 20.2, where the potential difference $V_B - V_A = -\vec{E} \cdot \Delta \vec{r} = -E \Delta r \cos \theta = -Ed = V_C - V_A$. Therefore, $V_B = V_C$. The name **equipotential surface** is given to any surface consisting of

Points B and C are at identical potential

Equipotential surfaces: continuous distribution of points have the same electric potential

Equipotential surfaces are \perp to the E-field lines

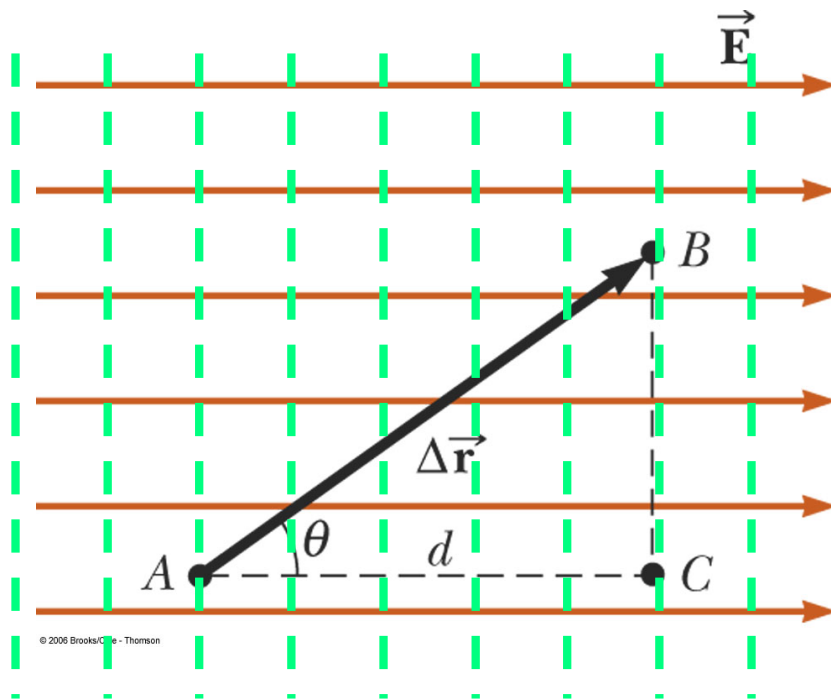

Points B and C are at identical potential



Similar to terrain maps, where contours denote levels of identical elevation

2 Oppositely-Charged Planes

Equipotential surfaces are parallel to the planes and \perp to the E-field lines

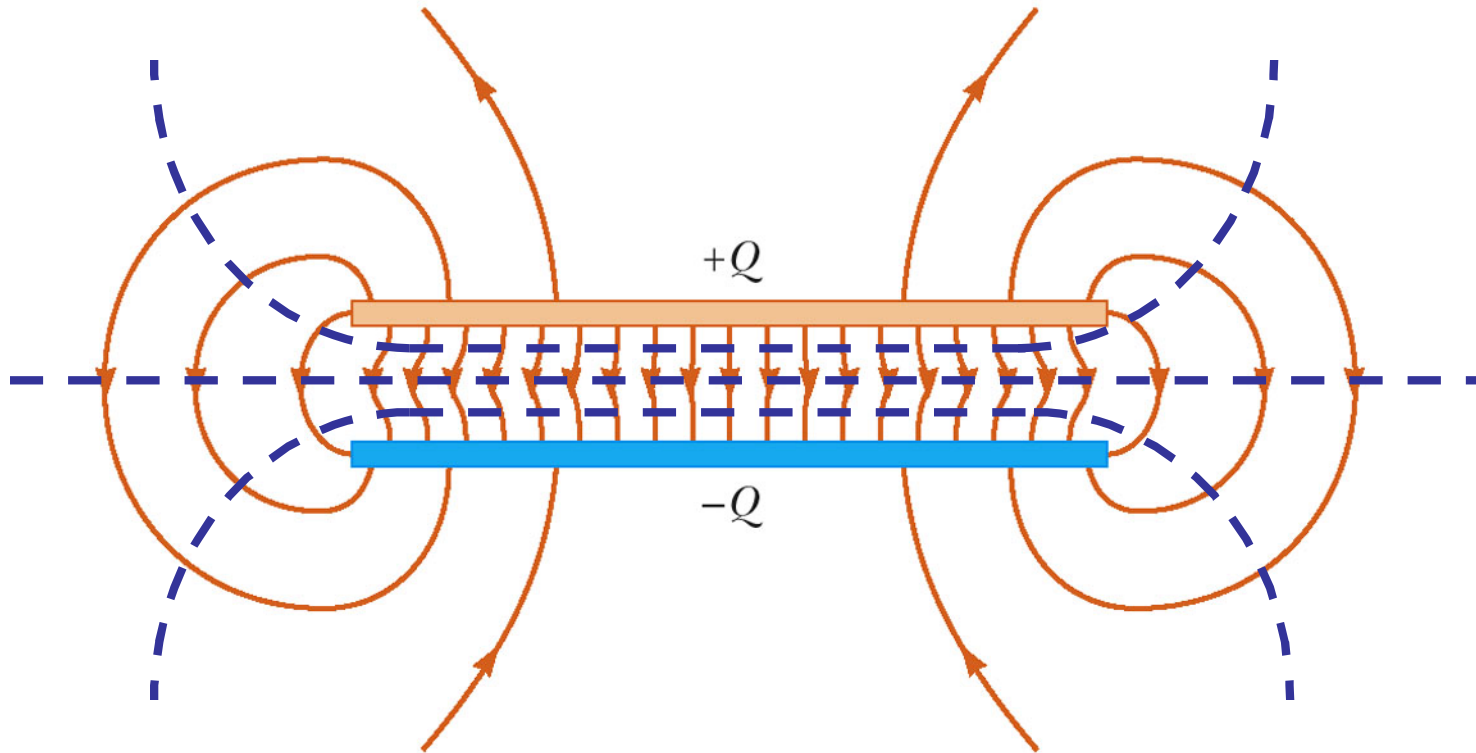

Potential vs. Potential Energy

POTENTIAL: Property of space due to charges; depends only on location

Positive charges will accelerate towards regions of low potential.

POTENTIAL ENERGY: due to the interaction between the charge and the electric field

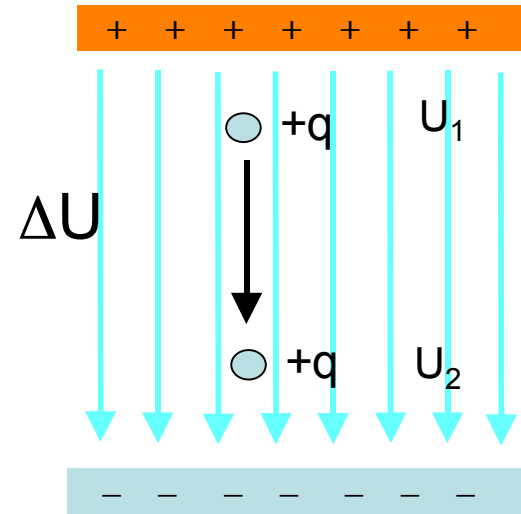
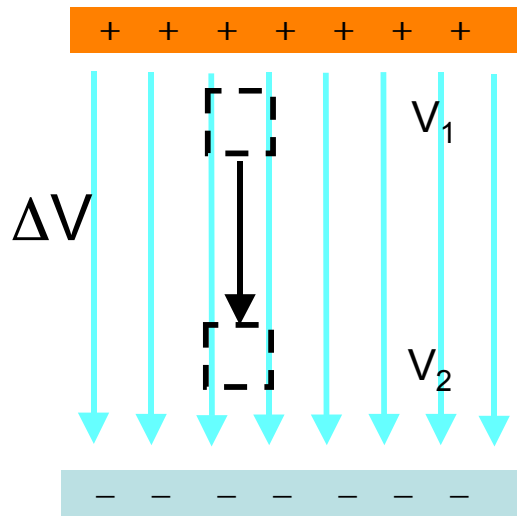

Example of Potential Difference

A parallel plate capacitor has a constant electric field of 500 N/C; the plates are separated by a distance of 2 cm. Find the potential difference between the two plates.

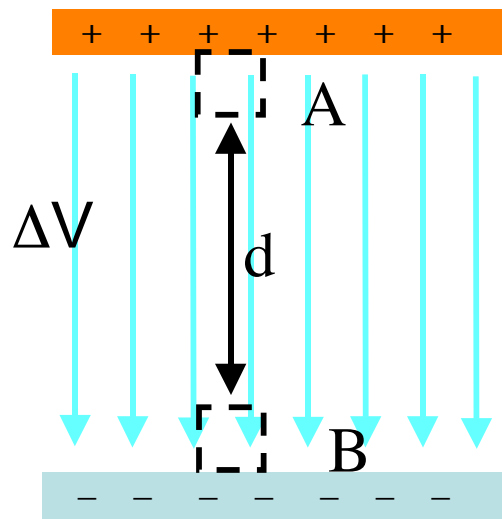

E-field is uniform, so we can use $\Delta V = -Ed = -(500\text{V/m})(0.02\text{m}) = -10\text{V}$

Remember: potential difference ΔV does not depend on the presence of any test charge in the E-field!

Example of Potential Difference

Now that we've found the potential difference ΔV , let's take a molecular ion, CO_2^+ (mass = 7.3×10^{-26} kg), and release it from rest at the anode (positive plate). What's the ion's final velocity when it reaches the cathode (negative plate)?

Solution: Use conservation of energy: $\Delta U = \Delta K$

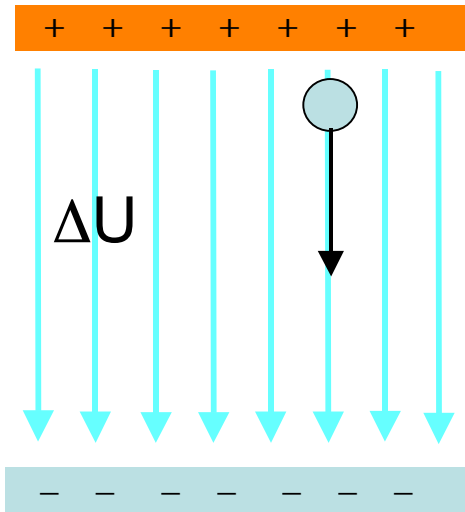

$$\Delta U = \Delta V q$$

$$\Delta K = \frac{1}{2} m v_{\text{final}}^2 - \frac{1}{2} m v_{\text{init}}^2$$

$$\Delta V q = \frac{1}{2} m v_{\text{final}}^2$$

$$v_{\text{final}}^2 = 2\Delta V q / m = (2)(10\text{V})(1.6 \times 10^{-19}\text{C}) / 7.3 \times 10^{-26} \text{ kg}$$

$$v_{\text{final}} = 6.6 \times 10^3 \text{ m/s}$$

Ch. 20.3:

Potential Energy U

Potential Energy Difference ΔU

Potential V

Potential Difference ΔV

For Single Point
Charges and for
Multiple Point Charges

An isolated, positive point charge produces an E- field directed radially outward. Let's calculate the potential difference between points A and B:

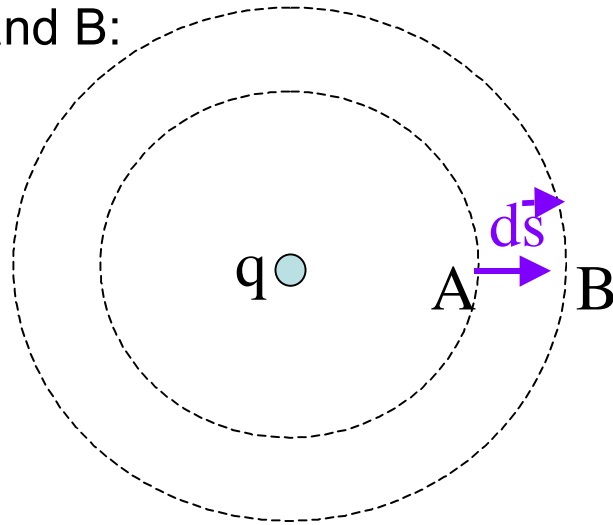

$$V_B - V_A = \Delta V = - \int_A^B \vec{\mathbf{E}} \cdot d\vec{\mathbf{s}}$$
$$\vec{\mathbf{E}} = k_e q / r^2 \hat{\mathbf{r}}$$

Here, $\hat{\mathbf{r}}$ and $d\vec{\mathbf{s}}$ are parallel.

We're going away from a positive charge, so V should decrease (expect negative ΔV)

$$\begin{aligned} V_B - V_A &= - \int_{r_A}^{r_B} k_e \frac{q}{r^2} dr = -k_e q \int_{r_A}^{r_B} \frac{dr}{r^2} = \frac{k_e q}{r} \Big|_{r_A}^{r_B} \\ &= k_e q \left[\frac{1}{r_B} - \frac{1}{r_A} \right] \end{aligned}$$

r_A is smaller than r_B , so $1/r_A$ is larger than $1/r_B$, so the term in brackets is negative

The electric field is conservative, and the electrostatic force is a conservative force, so The electric potential is independent of the path between points A and B. ΔV depends only on the RADIAL coordinates r_A and r_B !

- It is customary to choose a reference potential of $V = 0$ at $r_A = \infty$
- Then the potential at some point r is

$$V = k_e \frac{q}{r}$$

Dimensional arguments: For a constant field, $V = Ed$

For a point charge, V also has units of $E \times \text{distance}$

Equipotential surfaces for a point charge

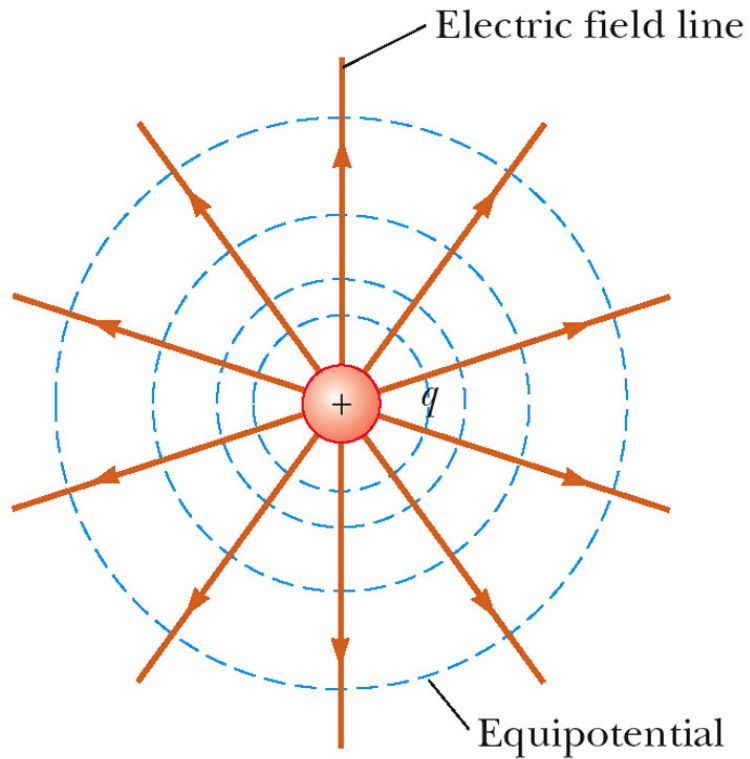

Note that E-field lines and equipotential surfaces are perpendicular

Calc V at $r=1\text{nm}$ from a proton

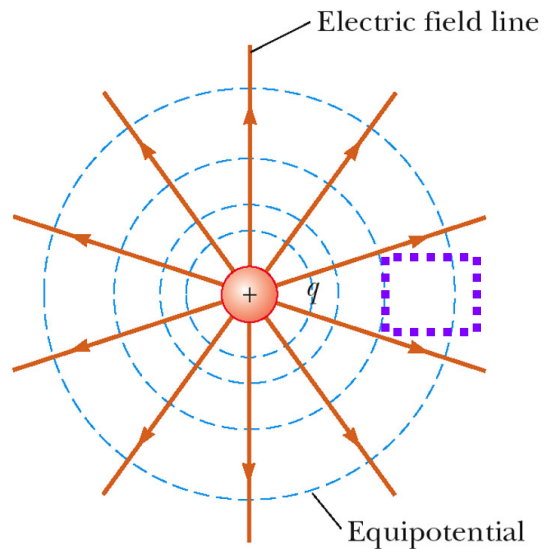

© 2006 Brooks/Cole - Thomson

$$V = k_e q / r =$$

$$(9 \times 10^9 \text{ Nm}^2/\text{C}^2)(+1.6 \times 10^{-19} \text{ C}) /$$
$$(10^{-9} \text{ m}) =$$

$$1.44 \text{ V}$$

Pot. Energy of 2 point charges

Consider a system of two charged particles, separated by a distance r

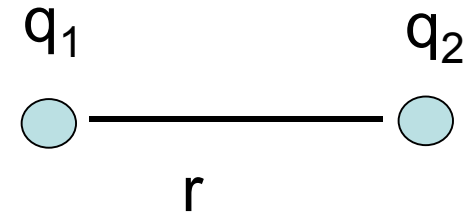

Define V_{21} as the potential due to the presence of charge q_2 at the location of charge q_1 .

$$V_{21} = \frac{k_e q_2}{r}$$

$$\begin{aligned} PE &= q_1 V_{21} = q_2 V_{12} \\ PE &= 0 \quad \text{at} \quad r = \infty \end{aligned}$$

$$U = k_e \frac{q_1 q_2}{r}$$

Pot. Energy of 2 point charges

$$U = k_e \frac{q_1 q_2}{r}$$

- If the two charges are the same sign, U is positive and work must be done (by an external agent) to bring the charges together
- If the two charges have opposite signs, U is negative and work would need to be done (by an external agent) to separate the charges.

Note:

When two LIKE charges are close together, the potential energy is positive (the higher the PE, the more likely the system is to come apart)

When two UNLIKE charges are close together, the potential energy is negative (the lower the PE, the more stable the system is)

Reminder: V & PE are scalar (not vector) quantities

Point charge q_1 :	$\vec{E} = k_e q_1 / r^2$	
Point charge q_1 :	$V = k_e q_1 / r$	(= $\vec{E} r$)
Point charge q_1 , introduce q_2 :	PE = $k_e q_1 q_2 / r$	(= $V q_2$)
Point charge q_1 , introduce q_2 :	$\vec{F}_E = k_e q_1 q_2 / r^2$	(= $\vec{E} q_2$)

Total Energy of a charge distribution

We will bring in two charges, each of $+1q$, from $r=\infty$ to $r=d$. How much work will be required (by us) to overcome the repelling E-fields?

$$\Delta PE = PE_{final} - PE_{init} = \frac{k_e q_1 q_2}{d} - \frac{k_e q_1 q_2}{\infty} \quad 0$$

(ΔPE is positive. Work done by us is positive.)

work done by E-field = $-\Delta PE$ is negative because the E-fields made “negative progress” in trying to separate the charges)

Total energy of system = amount of work needed (by us) to assemble the system = amount of energy stored in a chemical bond, for instance

Calc U required BY US to bring in a second proton from
 $r=\text{infinity}$ to $r = 1\text{nm}$

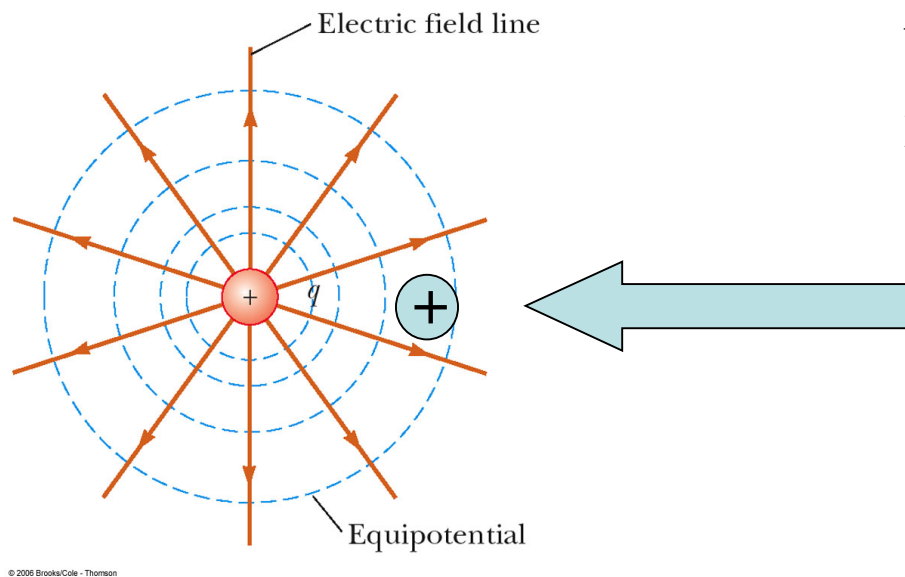

$$U = qV = (1.6\text{e-}19\text{C})(1.44\text{V}) = 2.3\text{e-}19 \text{ J} = 1.44 \text{ eV}$$

How about an electron?

The E-field, not us, does 1.44 eV of work this time.

V & U of atoms in a crystal lattice

In a crystal of salt (Na^+ & Cl^-) the distance between the ions is 0.24 nm. Find the potential due to Cl^- at the position of the Na^+ ion. Find the electrostatic energy of the Na^+ due to the interaction with Cl^- .

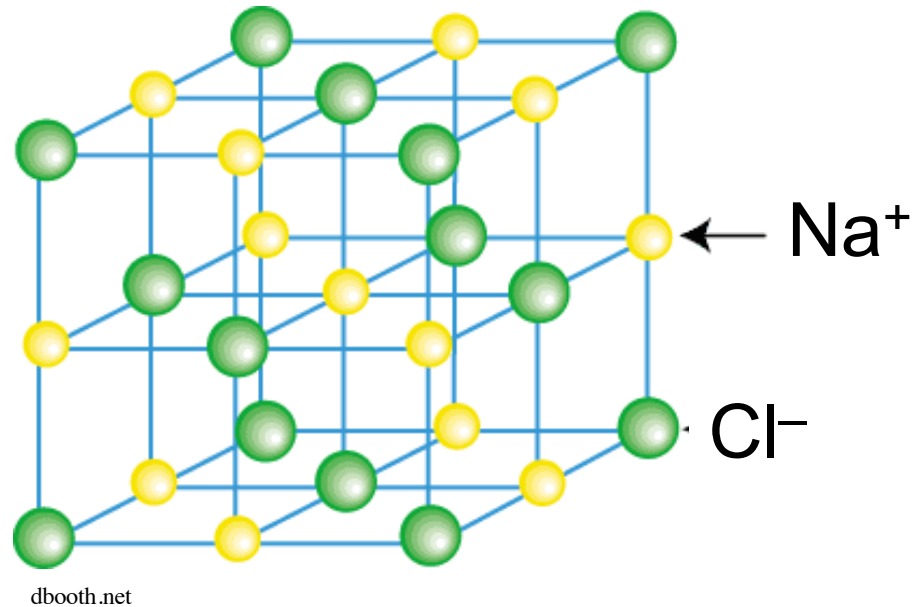
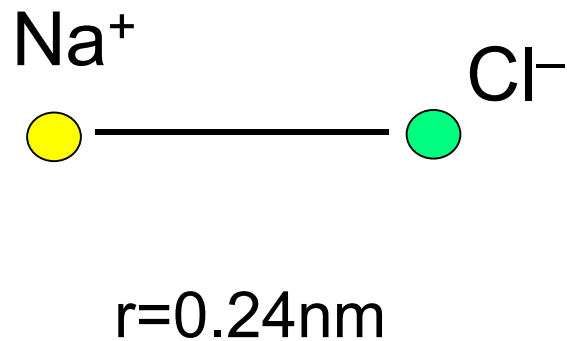

V & U of atoms in a crystal lattice

In a crystal of salt (Na^+ & Cl^-) the distance between the ions is 0.24 nm. Find the potential due to Cl^- at the position of the Na^+ ion. Find the electrostatic energy of the Na^+ due to the interaction with Cl^- .

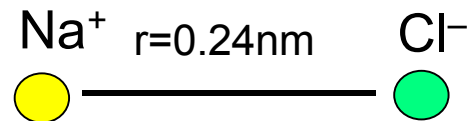
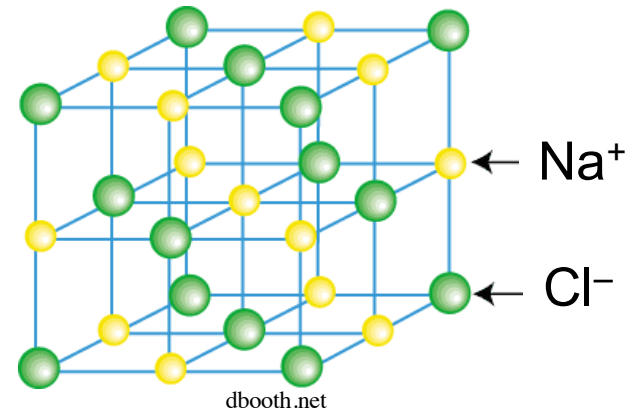

$$V = k_e q/r = 9 \times 10^9 \text{Nm}^2/\text{C}^2 (-1.6 \times 10^{-19} \text{C}) / (0.24 \times 10^{-9} \text{m}) = -6.0 \text{V}$$

$$U = qV = (1.6 \times 10^{-19} \text{C})(-6.0 \text{V}) = -9.6 \times 10^{-19} \text{J}$$

Recall definition of ELECTRON VOLT (convenient unit for atomic physics)

$$1\text{eV} = 1.6 \times 10^{-19} \text{J}$$

So $U = -6.0 \text{ eV}$ (energy in eV is $V \times$ the charge in units of e)

V at a point in space due to the E-field from multiple discrete charges nearby

$$V = k_e \sum_i \frac{q_i}{r_i}$$

V for a distribution of charges

Potential is a scalar: Total V at point A due to other charges = $V_{1A} + V_{2A} + V_{3A} + V_{4A} + \dots$

Ex.: Two protons are placed at corners of an equilateral triangle, with sides of 1 nm. Find the total potential at point A.

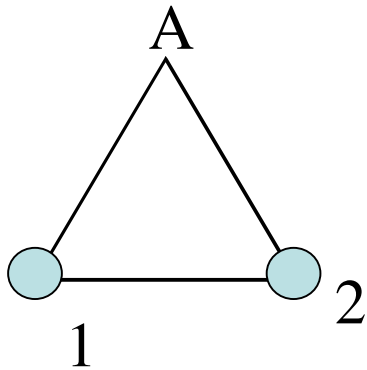

V due to each: $k_e q / r =$

$$(9 \times 10^9 \text{ Nm}^2/\text{C}^2)(1.6 \times 10^{-19} \text{ C}) / (10^{-9} \text{ m}) = 1.44$$

V

$$V_{\text{total}} = V_{1A} + V_{2A} = 1.44 \text{ V} + 1.44 \text{ V} = 2.88 \text{ V}$$

Example 20.3a: Total V due to 2 point charges

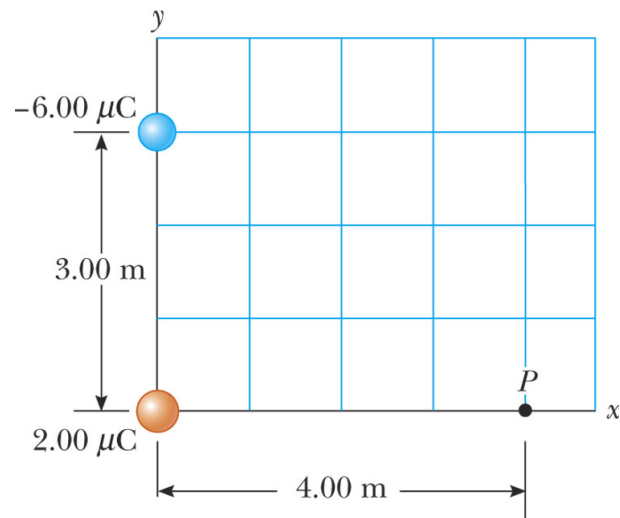

(a)

U for a charge distribution composed of multiple point charges

- If there are more than two charges, then find U for each pair of charges and add them algebraically
- The total electric potential energy of the entire system of point charges is equal to the work required to bring the charges, one at a time, from an infinite separation to their final positions

Total energy of a charge distribution

Suppose you have two protons already sitting at two corners of an equilateral triangle (1nm sides). You wish to bring in a third proton to the third corner. How much work is required (by us) to accomplish this?

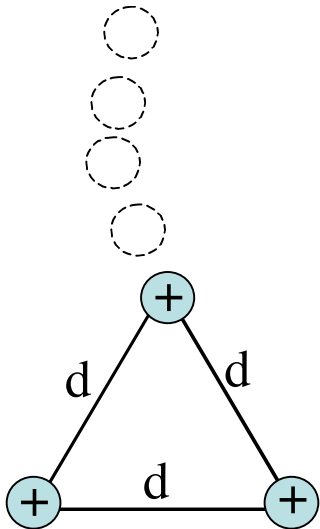

Total energy of a charge distribution

Suppose you have two protons already sitting at two corners of an equilateral triangle (1nm sides). You wish to bring in a third proton to the third corner. How much work is required (by us) to accomplish this?

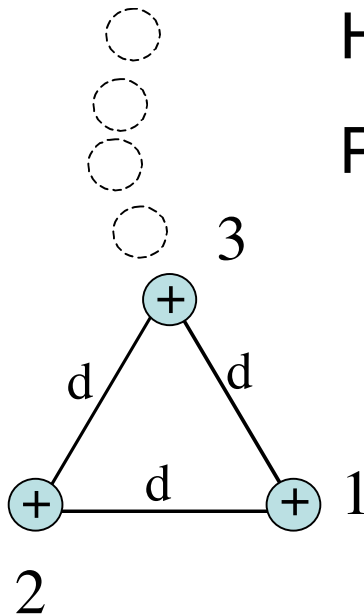

How many interactions? 2 (1&2 are already present)

$$PE = PE_{13} + PE_{23} = 2 (k_e q_1 q_2 / r) = 2k_e q^2 / r$$

Total energy of a charge distribution

Suppose you have two protons already sitting at two corners of an equilateral triangle (1nm sides). You wish to bring in a third proton to the third corner. How much work is required (by us) to accomplish this?

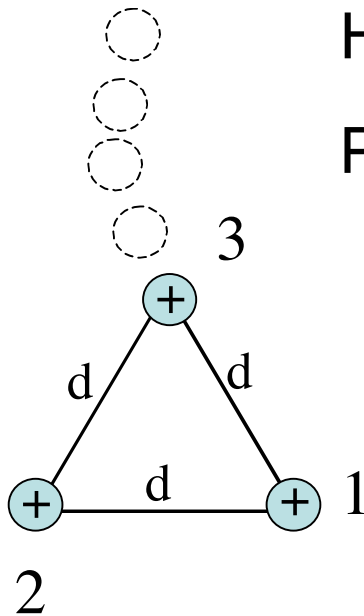

How many interactions? 2

$$PE = PE_{13} + PE_{23} = 2 (k_e q_1 q_2 / r) = 2k_e q^2 / r$$

$$PE = \frac{2 (9 \times 10^9 \text{ Nm}^2/\text{C}^2)(1.6 \times 10^{-19} \text{ C})^2}{10^{-9} \text{ m}}$$

$$PE = 4.6 \times 10^{-19} \text{ J}$$

(1eV = 1.6×10^{-19} J, so
this PE = 2.88 eV)

Total energy of a charge distribution

Suppose you wish to bring in THREE protons, from infinity to the corners of an equilateral triangle with sides having length 1 nm. How much work is required (by us) to accomplish this?

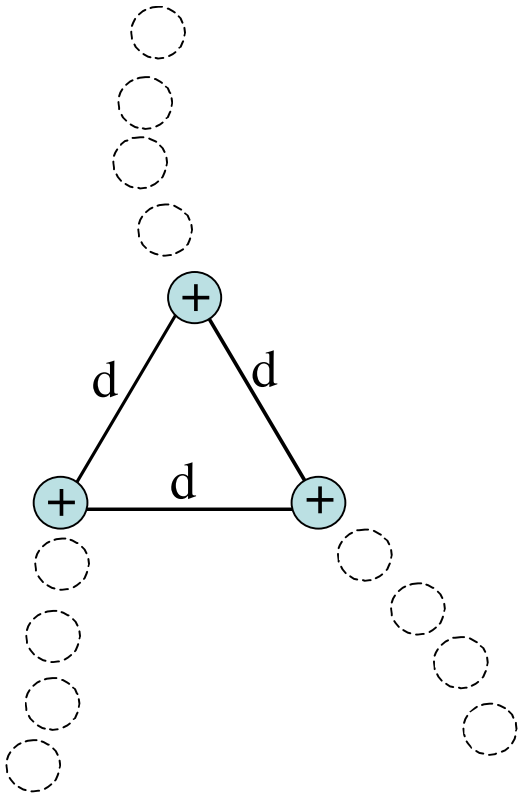

Total energy of a charge distribution

Suppose you wish to bring in THREE protons, from infinity to the corners of an equilateral triangle with sides having length 1 nm. How much work is required (by us) to accomplish this?

How many interactions? 3

$$PE = PE_{12} + PE_{13} + PE_{23} = 3 (k_e q_1 q_2 / r) = 3k_e q^2 / r$$

$$PE = \frac{3 (9 \times 10^9 \text{ Nm}^2/\text{C}^2)(1.6 \times 10^{-19} \text{ C})^2}{10^{-9} \text{ m}}$$

$$PE = 6.9 \times 10^{-19} \text{ J}$$

(1 eV = 1.6×10^{-19} J, so
this PE = 4.32 eV)

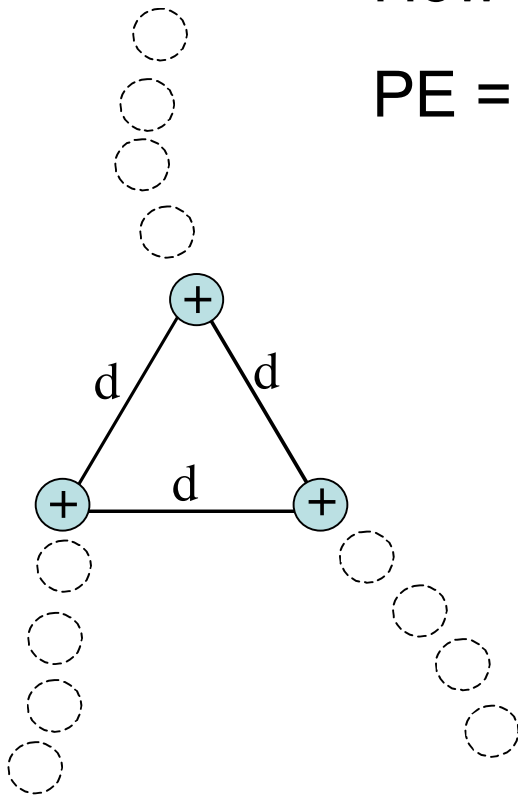

Total energy of a charge distribution

Suppose instead of 3 protons, you have 2 protons and 1 electron.

Now how much work would be required by us?

Note: pay attention to signs of each charge!

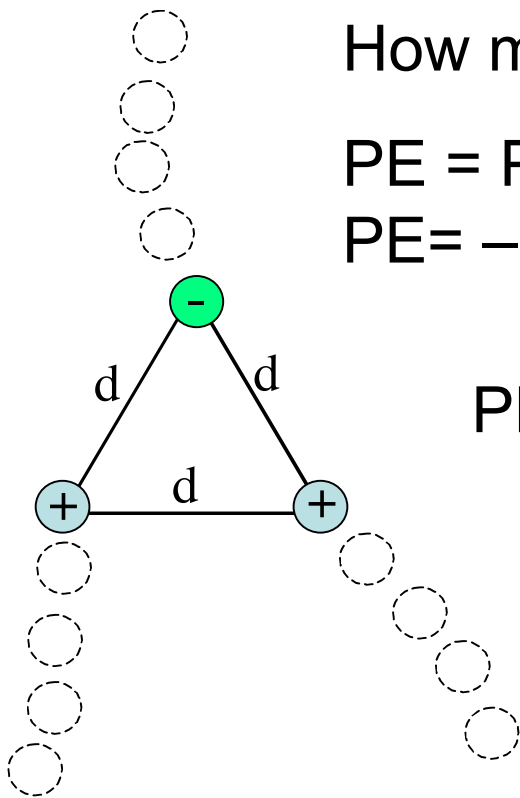

How many interactions? 3

$$PE = PE_{12} + PE_{13} + PE_{23} = +(k_e q^2/r) - (k_e q^2/r) - (k_e q^2/r)$$

$$PE = -k_e q^2/r$$

$$PE = \frac{-1 (9 \times 10^9 \text{ Nm}^2/\text{C}^2)(1.6 \times 10^{-19} \text{ C})^2}{10^{-9} \text{ m}}$$

$$PE = -2.3 \times 10^{-19} \text{ J} = -1.44 \text{ eV}$$

Total P.E. is less than before (in fact, negative):
distribution is MUCH more stable!

Which is more stable?

That is, which has the lower total P.E.?

(closer to $-\infty$ \rightarrow more stable)

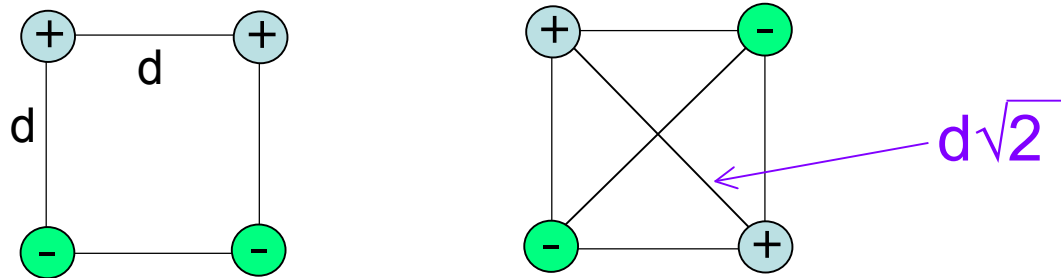

Total PE = PE of each side + PE of each diagonal

$$PE_{\text{side}} = k_e q_1 q_2 / d \quad (\text{pay attention to signs of charges!!!!})$$

$$PE_{\text{diagonal}} = k_e q_1 q_2 / (d\sqrt{2})$$

Which is more stable?

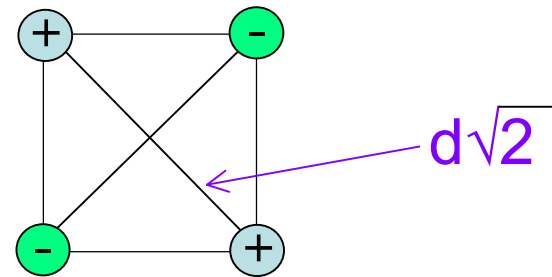
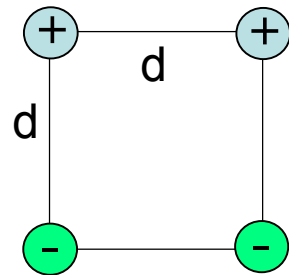

Define $PE_0 = k_e q^2/d$

We will do this part in lecture on Thursday....

Sides: PE_0 +2 -2

Diag.: $PE_0/\sqrt{2}$ -2 +2

Total PE $(-2/\sqrt{2}) PE_0 = -1.41PE_0$ $(-4 + 2/\sqrt{2})PE_0 = -2.59PE_0$

Yes, this distribution is stable....

... but this one is **MORE** stable!